

SCH

(SUPPLIES) LIMITED

Manufacturers & Suppliers of Estate & Garden Machinery
TELEPHONE 01473 328272 • FAX 01473 327177
www.schsupplies.co.uk

OPERATING INSTRUCTIONS

MUST BE READ PRIOR TO OPERATING THIS MACHINE



Towed Sweeper

Ref: TS98

DESCRIPTION

The TS98 lawn sweeper/collector is robust in construction to withstand prolonged heavy use. A differential mechanism on the brushes allows the sweeper to be maneuvered in tight corners without the wheels "scuffing". The differential mechanism also allows both ground wheels to drive the pick-up brushes giving it superior sweeping power.

The height adjustment is simple. The main drive is transmitted via metal gears. The large capacity solid plastic catcher is rot and tear proof and simple to use. Reversing into the tipping heap is always difficult but it is made easier with the TS98 as it only has two wheels in contact with the ground. A useful collection sheet is supplied with each unit.

SPECIFICATIONS

Overall Width	1300mm (51")
Working Width	915mm (36")
Length with tow bar	1700mm (67")
Catcher Capacity	270 Litres
Weight	78kg

SAFETY INSTRUCTIONS

- When transporting the sweeper ensure the brush adjuster is moved to its highest position, bringing the brushes out of work.
- Never leave the sweeper on or around the playing areas. Always remove it to a place of safety before activities commence.
- On small to medium sized areas, only the towing vehicle operator should be present.
- Always make sure the unit is securely connected to the towing vehicle before use.
- Never travel at excessive speeds – Max speed 4 ½ mph
- Do not allow the sweeper to bounce
- Never allow any person to travel on the sweeper.

IT IS NOT TO BE USED FOR COLLECTING HAY TYPE GRASS

If in doubt, please call the SCH customer help line at **01473 328272**

IMPORTANT

When the sweeper is attached to the tractor ensure that the floor of the catcher is parallel with the ground. This is achieved by plus and minus on the adjuster on the underside of the tow bar adjacent to the swivel.

GENERAL

The brush adjuster bar raises the brushes up and down. It is imperative that the brush is set to the correct height.

Please note:

When the sweeper is working the brushes should just 'tickle' the surface they are sweeping. The brush uses a flicking action rather than a mechanical action to collect debris. If the brush level is set too low this will put excess strain on the brush and in turn damage the metal gearing in the wheel assembly.

The position three hole is recommended. The remaining two holes at the top of the adjuster bar are for use as the brush tips wear down.

FITTING & TOWING

Fixing the tow bar to the sweeper:

The bolt is positioned through one side of the sweeper fixing point, through the tow bar pivot and the other side of the sweeper fixing point. Tighten the nut ensuring that the tow bar can still pivot. A 10mm bolt and nut are supplied.

Fitting the catcher to the sweeper:

The bolts are positioned in the arms of the sweeper. Mount the catcher over the sweeper arms and place the bolts through the catcher, secure with nuts. 2 x 8mm nuts and bolts are supplied.

EMPTYING THE SWEEPER

To empty the catcher box there is a metal hand grip. Place your hand in the grip and raise the box upwards. The box will pivot and the collected mass will drop. A few shakes may be needed to empty the box of stubborn sweepings. With the box in the raised position drive the tractor forward. Lower the box and re commence sweeping. A collection sheet is included.

The sweeper can also be reversed into the compost heap; lift the box up to empty. Always reverse extremely slowly. If the sweeper 'jack knifes' pull forward and start again.

N.B. When reversing the sweeper remember to lift the brushes out of contact with the surface

MAINTENANCE

The unit must be washed down after use, removing any mud and debris on and around the brushes. Build-up of mud on the brushes will reduce the life of the gearing.

After every 10 hours of work or once a year, whichever is the soonest the brush differential must be greased.

1. Locate the grease nipple situated in the center of the brush section.
2. Clean out the orifice.
3. Pump 2-3 strokes of grease into the nipple.
4. Rotate the wheels for a number of revolutions clockwise.
5. Repeat step 3.
6. Rotate the wheels for a number of revolutions anti clockwise.

Yearly Service:

Remove the drive wheels by undoing the center nut. Draw off the wheels. Clean the drive cogs, re-grease and replace the wheels.

PARTS LIST FOR TS98

Part Ref	Description	Quantity
01	Catcher	1
02	Handle for catcher	1
03	Nut & bolt	2
04	Brush Height Adjuster	1
05	Brush Height Adjuster Clip	1
06	Brush pick-up plate	1
07	Bearing for brush shaft	2
08	Bearing housing	4
09	Bearing Sleeve	2
10	Brush shaft	1
11	Brush shaft including link pin	1
12	Brushes	4
13	Nuts & bolts	4
14	Pinion gear	2
15	Frame including stub axle	1
16	Washer	10
17	Dust cover back plate	2
18	Dust seal	2
19	Dust cover	2
20	Oil lite brush	2
21	Drive gear including studding and nuts	2
22	Drive gear washer / spacer	4
23	Drive wheel	4
24	Nylon washer	2
25	Washer	4
26	Nylock Nut	2
27	Bolt	2
28	Height adjuster bolt	1
29	Tow bar fixing bolt	1
30	Tow bar	1
31	Black frame end caps	4
32a	Grease nipple	1

32	Collection Sheet	1
33	Rubber strip attachment	1
TS98BOXCOV	Mesh cover for box	1

Please contact us for help with spare parts.

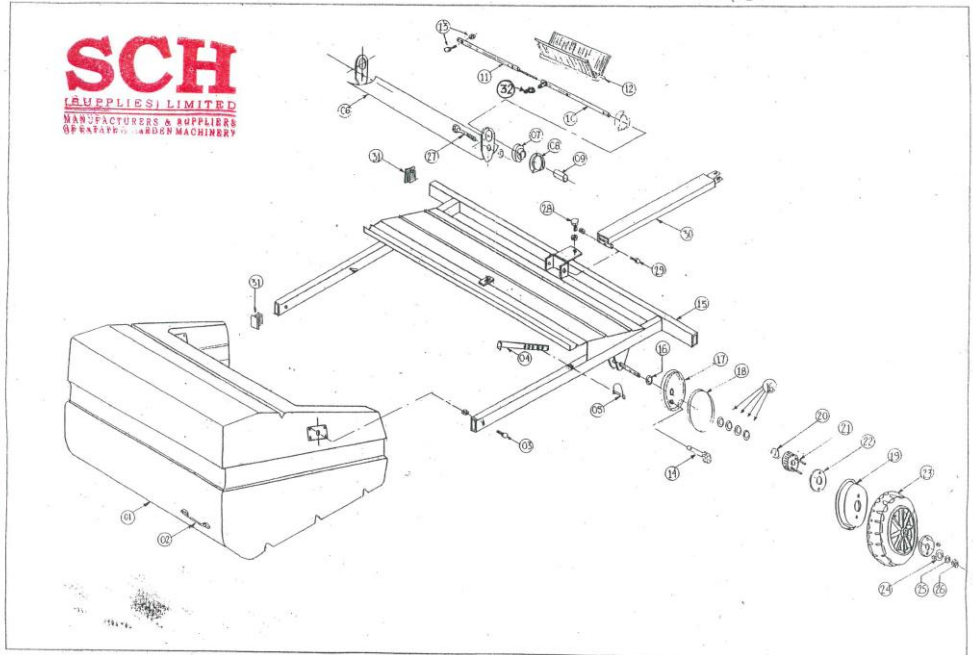

WARRANTY

Your Towed Sweeper is guaranteed for 12 months from date of purchase. This guarantee covers faults which may occur from defective parts or manufacture



If you are missing your free brochure contact us on
01473 328272, email sales@schsupplies.co.uk, or
visit our website www.schsupplies.co.uk

