

WINTON FINISHING MOWER

WFM SERIES



OWNERS MANUAL

PLEASE READ THIS MANUAL BEFORE OPERATING THE MOWER

Congratulations on purchasing your new **Winton** mower!

Before you get started, we have provided a helpful space to jot down a few important details about your new Winton machine.

Model Number: WFM

Serial Number:

Date of purchase:

Factory Reference: FMN120 / FMN150 / FMN180

This manual should be considered a permanent part of this machine and should remain with it even if the machine is subsequently sold.

Winton continually seeks advancements in its product design and quality. Therefore, while this manual contains the most current product information available at the time of printing, there may be minor discrepancies between your machine and this manual.

If you have any questions concerning this manual, please consult your local dealer.

General Safety Information

Ensure all potential operators read this manual thoroughly before using the machine.

Safety: Ensure tractor and machine is stopped & keys out of ignition before set-up/maintenance.

Safety: Failure to follow good safety standards could result in severe injury or even death.

Misuse: This machine is designed for use with compact tractors, and should be used only for the indicated purpose. Winton does not take responsibility if the machine is used for any other purpose. Children must not operate the machine under any circumstance.

Modification: Do not modify equipment in any way. This may impair the operation and overall safety of the machine.

Tractor requirements: Use only with compact tractors within power range specified.

Misuse transport: Do not use machinery to transport personnel or livestock.

Condition: For the safety of personnel and optimum performance of the machine, you should check the condition of the machine and the tractor before starting. Before use check all nuts and bolts are tight.

Spatial awareness: Always check the operating area is safe before starting machinery.

Operator clothing: The operator should not wear loose clothing while operating machinery.

Safety wear: Always use appropriate ear protection when running a tractor and machinery. Ensure you are wearing protective gloves when servicing and using machinery.

Bystander safety: Ensure bystanders keep away from the machine when it is in use. Do not touch moving parts when the machine is at work.

Public places: When travelling on the road/public places, always keep the PTO turned off.

Maintenance: Always keep the machine maintained and in a good state. Where necessary, repair or replace any defective parts. Do not modify the machine.

Sharp objects: Pay attention to the sharp/pointed parts while servicing the machine.

Safety guards: All protective parts should be in good condition before operating machinery.

Safety signs/stickers: Keep all safety signs clean and legible. Replace any which are missing or illegible. If a component with safety sign/(s) is replaced, make sure new safety sign/(s) are attached in the same locations.

Operating speeds: Machinery and PTO should be operated at the recommended speed at all times.

Safety awareness: Good safety requires that you familiarise yourself with various safety signs, the type of warning and the area, or particular function related to that area.

Alertness: Never consume alcohol or drugs these can hinder alertness/coordination. Consult your doctor about using this machine while taking prescription medications.

General Safety Information (continued)

Machinery Pre-Use Checks

On receipt of your new Winton machine and again within the first 4 hours of use, or the 'shake in' period as we like to call it, we always recommend checking over the machine.

- Check all bolts, nuts and screws are tight on the unit.
- Tighten/check any bolts and nuts securing blades.
- If your machine has belts check the tension and adjust if required.
- Apply grease to grease points if necessary.
- Check gear oil level and top up if needed. Do not overfill.

Tractor Pre-Use Checks

Check that the machine is properly attached to the tractor. Ensure that secure pins are used on the linkage mounting pins.

Be sure to add extra weights to the front of the tractor or add wheel weights if required.

Check that the tractor PTO shaft turns freely and that the machines PTO drive shaft can extend easily. Grease the PTO drive shaft using the grease points.

The chain on the PTO shaft should be checked and in a good condition. The universal joints installed should be in a good state, with proper protective parts.

Before installing the PTO shaft, the tractor and machine should be stopped and remove the key.

Install and secure all safety guards, doors and covers before starting.

Bystanders should leave the immediate area before connecting the drive from the tractor.

Running/Operating Checks

- Always keep the PTO output from the tractor at **540 RPM** when running machinery.

Post-Use Regular Checks

Check blades, belts and wearing parts. Be sure they are not damaged and blades swing freely in their mount. Repair or replace as required.

Clean machinery and check for/clear any entangled material which may have got stuck around any rotating parts.

CONTENTS

	Pg.
General Safety information	1-2
1. Dimensions and Specifications	3
2. Installation & Set Up	4
3. Cutting Height Adjustment	5
4. Gear Oil Change & Check	6-7
5. Adjusting Belt Tension	8
6. Linkage Extension	9
7. Servicing & Maintenance	10-11
8. Parts Diagram & Parts List 1	12-15
9. Parts Diagram 2 & Parts List 2	16
10. Parts Diagram 3 & Parts List 3	17
PTO Shaft Resizing	19
Winton Product Warranty	20
Trouble Shooting	21

1. Dimensions & Specifications

Model	WFM120	WFM150	WFM180
Weight	178kg	187g	202kg
Working Width	120cm	150cm	180cm
Number Of Blades	3	3	3
Recommended Tractor HP	16 - 30hp	20 - 45hp	25 - 55hp
Width	130cm	160cm	200cm
Depth	125cm	135cm	145cm
Height	75cm	75cm	75cm
PTO Shaft Size	70-100cm	70-100cm	70-100cm
Cutting Height	2 - 8cm	2 - 8cm	2 - 8cm
Linkage Size	Category 1	Category 1	Category 1
Number Of Drive Belts	2	2	2

2. INSTALLATION & SET UP

Safety: Ensure tractor and machine is stopped & keys out of ignition before set-up/maintenance.

Safety: Before attaching/detaching machinery ensure the hydraulic lift system is in a neutral position.

Safety: Make sure the PTO drive isn't connected at any point until instructed to do so.

You will need:

Your tractor, tractor top link arm (adjustable), linkage pins, PTO shaft & some elbow grease!

Attaching The Mower

Start by finding a flat piece of ground. Lower the three point linkage on your tractor to its lowest position and attach the mower to the tractor using the three point linkage pins and linch pins. Attach the top linkage arm to the floating top link to allow the mower to "float" behind the tractor [see section on linkage extension].

Ensure that all four wheels are level on the ground when attached. Check the clearance between the bottom of the blades and the ground, this should be at least 20mm.

The cutting height can be set by adjusting the wheel spacers on the machine to increase or decrease the blade clearance as required [see section on adjusting the cutting height].

The working speed of the machine should always be at a walking pace (approx. 2 to 5 mph) depending on the working conditions. Longer patches of grass should be cut at a much slower pace for the best cut and to avoid any damage to the mower. Remember, finishing mowers are designed for shorter frequently maintained grass. You may need to cut or top any overgrown areas first before using the finishing mower.

Check your PTO shaft's grease points and apply grease if needed. Then attach the PTO drive shaft and ensure the locking pin is secure on both the tractor and mower sides. Attach the chain to a secure point on the tractor/implement.

Operate the mower the with tractor in low range gear and the PTO delivering 540 RPM.

Pre-Mowing Checklist

Before starting the machine, always check and adjust the following:

- Set correct cutting height. [Section 3]
- Oil level of the gearbox. [Section 4]
- Check the belt tension. [Section 5]
- Lubrication/grease points. [Section 7]
- Tightness of all bolts, nuts and screws.
- All protective guards are in place before operating.

3. CUTTING HEIGHT ADJUSTMENT

Safety: Ensure tractor and machine is stopped & keys out of ignition before set-up/maintenance.

Note: Clearance of blades to the ground should be at least 20mm and higher on un-even ground.

Getting the cutting height right is the key to creating the best cut and finish when mowing. The cut height can be set by simply adjusting the mower deck height with the wheel spacers.

There are different sizes of adjusting spacers on the wheel forks which can be used to achieve a range of cutting heights. The spacers are moved from under and above the wheel bracket to achieve the desired height.

Always make sure all spacers are in the same position on all wheels to ensure an even and level cut.

Wheel Adjustment

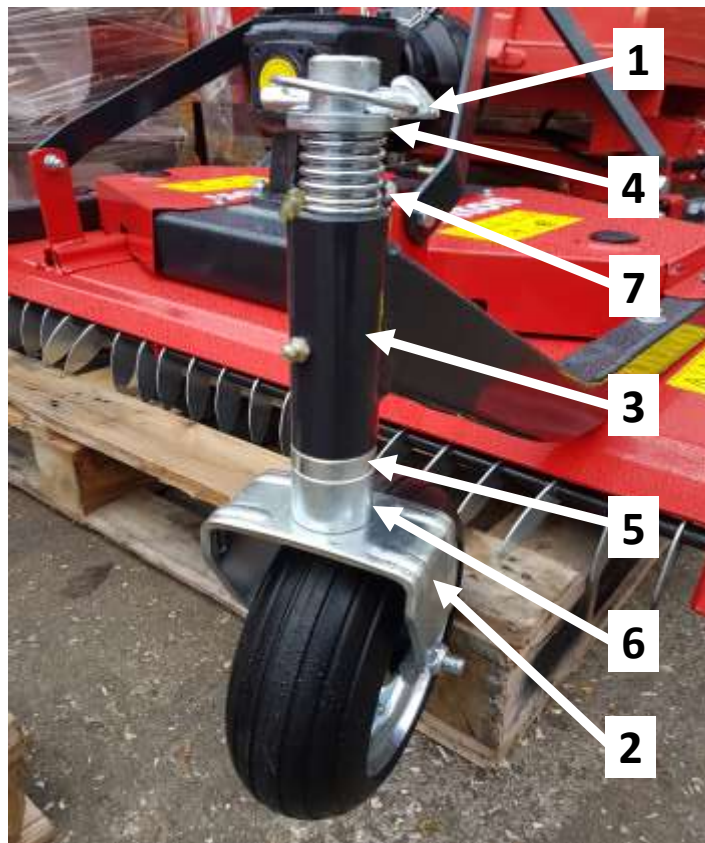

1. Use the tractor linkage and secure stands to raise the mower off the wheels.
2. Remove linch pin **1** and slide wheel fork **2** out of bracket **3**.
3. Position spacers **4**, **5** & **6** above or below the wheel bracket as required.
4. Position the spring **7** on the bracket.
5. Replace wheel fork **2** and linch pin **1**.
6. Repeat above on the remaining three wheels.

4. GEAR OIL CHANGE & CHECK

Safety: Ensure tractor and machine is stopped & keys out of ignition before set-up/maintenance.

Safety: Always follow manufacturers instructions for oils and lubricants.

Important Information

Gear Oil Grade	80w90 gear oil for all conditions (or equivalent)
Gearbox Oil Level	Approx. 0.5 litres to level plug
Level Plug Size	8mm Allen key
First Oil Change	50 hours use
Oil Change Frequency	250 hours/yearly (whichever is first)

Do not mix old and new oils together or mix different types of oil. Always dispose of old oils in the safely and in the correct manor.

Always make sure the machine is on a flat and level surface when checking oil levels. The machine should be left at a standstill to cool down for at least 10 minutes. Ensure the machine is stable before carrying out work and will not upturn.



4. GEAR OIL CHANGE & CHECK (Continued)

Safety: Ensure tractor and machine is stopped & keys out of ignition before set-up/maintenance.

Safety: Always follow manufacturers instructions for oils and lubricants.

Oil Change/Check Gearbox

1. Remove filler/breather plug **1** on top of the gearbox unit.
2. Remove level plug **2** on the side of the gearbox.
3. Add oil through the filler/breather **1** (if required). The oil should reach/begins to weep from level plug **2**.
4. Replace filler/breather plug **1** and level plug **2**.

Draining oil: Use an oil pump to remove old oil and any debris when changing oil.

Bolt tension: Always make sure bolts are tightened correctly. The filler/level plug should be secure but not over tightened.

Oil Change Log

Oil Change #1	Oil Change #2	Oil Change #3	Oil Change #4	Oil Change #5	Oil Change #6
/ /	/ /	/ /	/ /	/ /	/ /

5. ADJUSTING BELT TENSION

Safety: Ensure tractor and machine is stopped & keys out of ignition before set-up/maintenance.

Correct Belt Tension

The correct belt tension is achieved when the belt can be deflected by the belt thickness about 10mm at the centre point between the pulleys. A generic measure across machines is the belt should be able to twist a quarter turn by hand. Any more and they are too loose and any less and too tight, you may run the risk of losing drive to the mower or burning the belts out prematurely.

Always use a straight edge to make sure the belt pulleys are in line and running true. If misaligned, contact your dealer or service engineer for technical support.

Belt Tensioning

1. Remove bolts **1** on the wheel brackets then bolts **2** on the guard by the gearbox.
2. Remove both belt guard panels to gain access to the belts.
3. Loosen off bolt & nuts **3**.
4. Wind in/out bolt **4** and nut **5** to tension the belts as required.
5. Replace and tighten bolt & nuts **3** and replace belt guards.
6. Replace and tighten bolts **1** and **2**.

To change belts, loosen off the belt tension. They are a tight fit and will need some elbow grease.

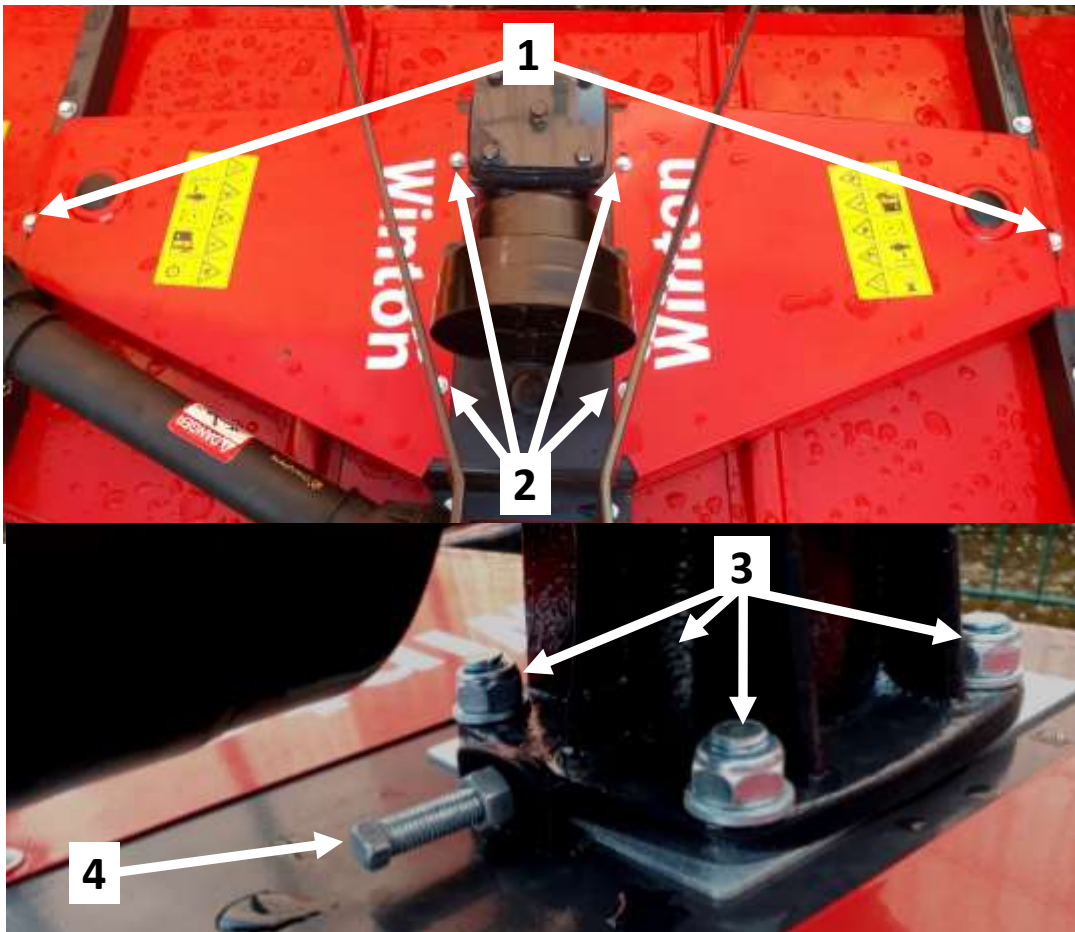

6. LINKAGE EXTENSION

Safety: Ensure tractor and machine is stopped & keys out of ignition before set-up/maintenance.

Some tractors with shorter lower linkage arms or larger rear tyres may find that attaching the finishing mower causes the tractor wheels to touch the mower wheels. In these cases linkage extensions can be supplied to prevent the problem.

The lower linkage extenders **A** can be attached or detached as required. These are simply bolted to the A frame bracket on the mower. The lower linkage pins can be moved between the extension brackets and mower as needed.

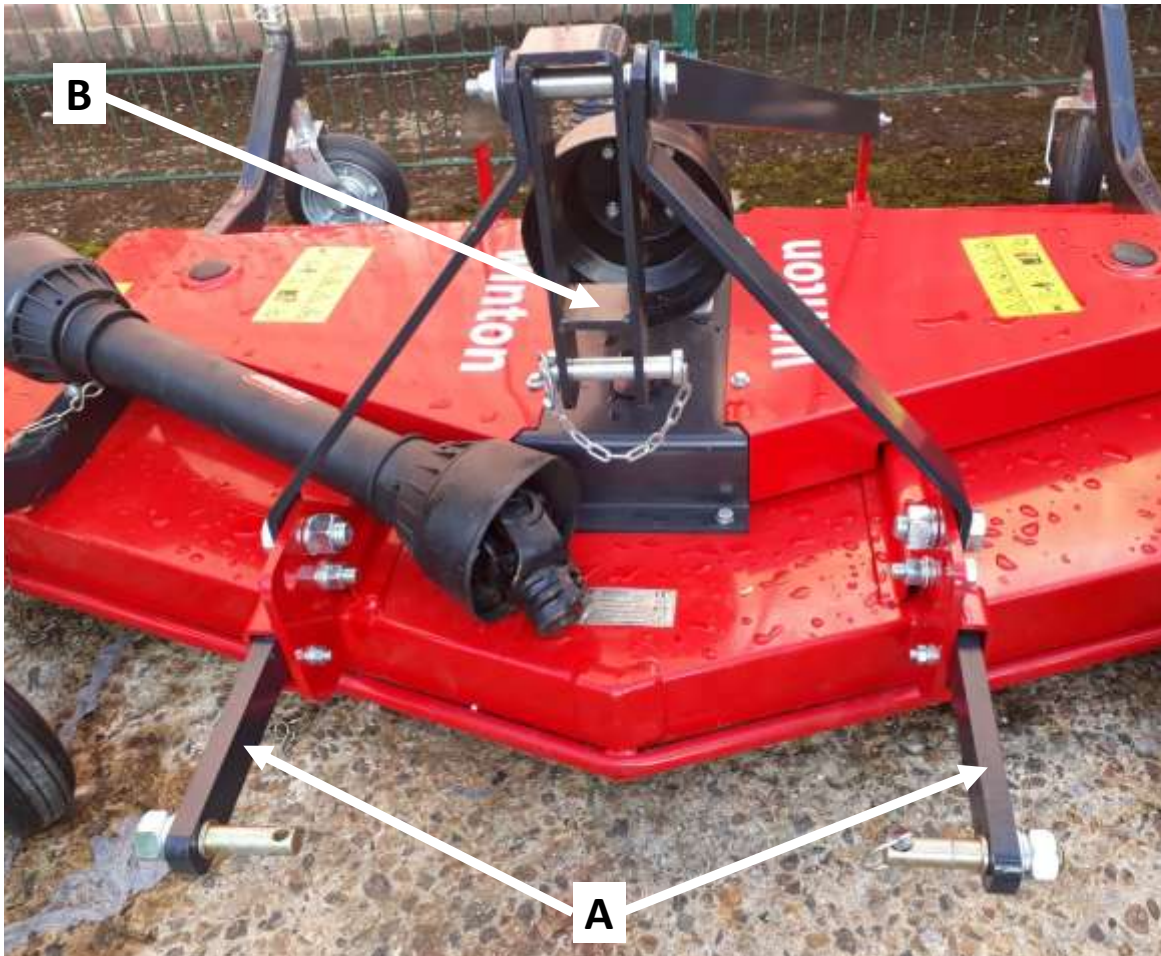

The mower also has a floating top linkage **B**. This is not fixed into place which allows the mower to remain on all wheels over any bumps or contours in the ground.

Lift the floating linkage **B** by hand and attach to the tractor as you would with a fixed top linkage point. Adjust the tractor's top linkage arm so the linkage is secure.

Always take extra care if lifting the tractor's 3 point linkage when the mower is attached. As the floating top linkage is not rigid the mower is likely to be unstable. Use a fixed point for any lifting.

7. SERVICING & MAINTENANCE

Safety: Store all lubricants away from excessive heat, dust, moisture and contaminants.

Safety: Ensure tractor and machine is stopped & keys out of ignition before set-up/maintenance.

Grease Type	Multi-purpose lithium based grease
Grease Frequency	Check every 4-8 hours (top up if required)

Greasing & Lubrication Points

1. Blade Hubs x3 (underneath the bungs) **1**.
2. Wheel Fork Tubes x4 **2**.
3. Wheels x4 **3**.
4. PTO shaft x2

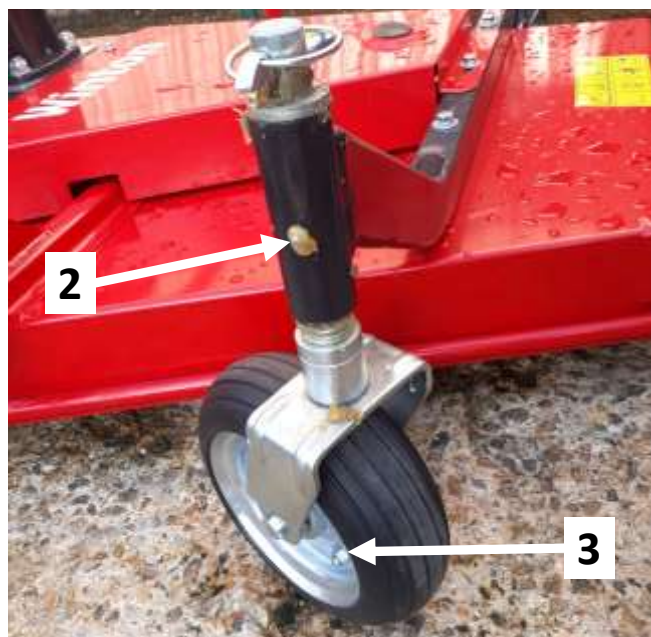
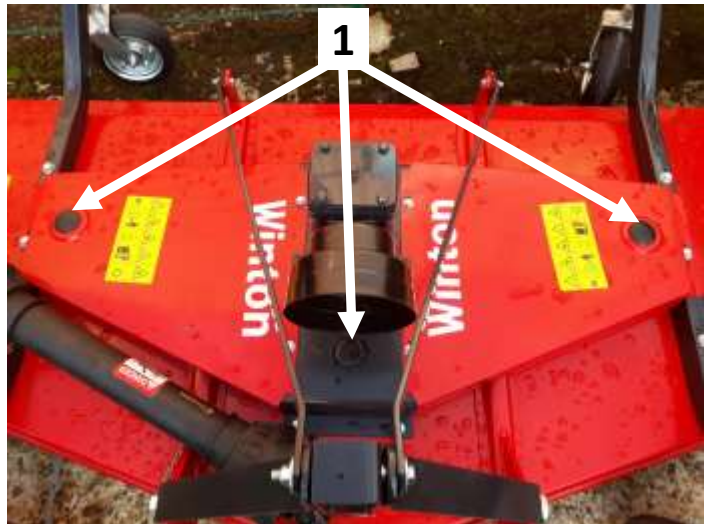

7. SERVICING & MAINTENANCE (Continued)

Safety: Store all lubricants away from excessive heat, dust, moisture and contaminants.

Safety: Ensure tractor and machine is stopped & keys out of ignition before set-up/maintenance.

Wipe grease nipples with a clean cloth before greasing to avoid injecting any dirt and grit. Press grease into each grease nipple three to five times. We recommend using a hand-held grease gun for best results.

If grease nipples will not take grease, remove and clean thoroughly. Also clean lubricant passageway. If you notice any grease points are broken replace or repair them immediately.

Other Maintenance

Blades: Check condition of the blades and replace if worn/broken. Always take care when handling blades, wear gloves and use suitable tools for changing blades. If blades are replaced check they are secure to avoid any excessive vibration.

Oils: Ensure oil levels are checked and topped up when needed. Replace any oils per the schedule.

PTO Shaft: Check the condition of your PTO shaft and replace if worn or damaged immediately.

Cleaning: Ensure the mower deck is cleaned of mud and grass. Remove debris from any moving parts to prevent entanglement. Do not spray water on bearings when cleaning with a high pressure washer.

Bearings: Check the bearings on the three blade hubs. If the oil seals are damaged debris may enter the bearings. Clean and replace with new bearings if necessary. Run the mower without a load for approx. 3-5 minutes to check bearings are operating smoothly.

Paintwork: Re-coat any damaged paintwork to prevent corrosion.

Wheels: Check the condition of all wheels and replace if any are broken or damaged.

Storage: Store the machine in a dry, level area. Chock the wheels if necessary.

Belts: Check the condition of belts, replace if worn or frayed. Tension belts if required.



*The periods recommended are based on normal operating conditions. Severe or unusual conditions may require more frequent maintenance.

8. PARTS DIAGRAM 1

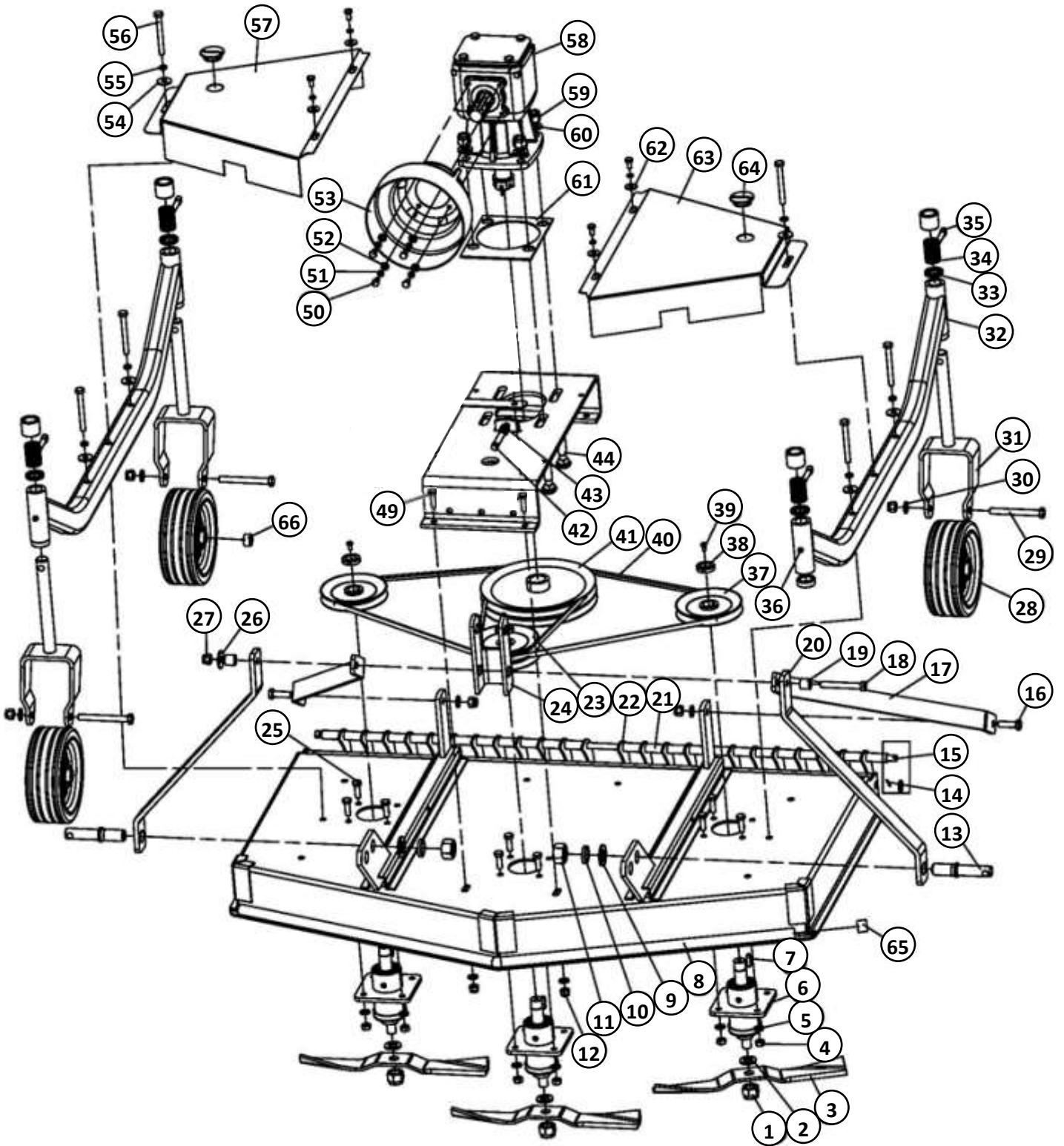

8. PARTS LIST 1

Dia No.	Number	Part Number	Part Description	Qty
1	503010766	DIN985-M18	blade lock nut M18	3
2	506010060	GB97.1-18	plain washer 18	3
3-1	702110080	FM120.00.118	(L1=410) blade 120	3
3-2	702110081	FM150.00.118	(L1=510) blade 150	3
3-3	702110082	FM180.00.118	(L1=610) blade 180	3
4	503010046	GB6170-M10	blade seat nut M10	12
5	506010056	GB97.1-10	blade seat plain washer 10	16
6	802190010	FMN120.00.012	blade seat assembly	3
7	507010070	GB1096-A-8X7X28	flat key/woodruff key 8x7x28	3
8-1	802190013	FMN120.00.013	hood/deck 120	1
8-2	802200001	FMN120.00.013a	hood/deck 150	1
8-3	802210004	FMN120.00.013b	hood/deck 180	1
9	506010063	GB97.1-24	lower linkage plain washer 24	2
10	506030043	GB93-24	lower linkage spring washer 24	2
11	503010053	GB6170-M24	lower linkage nut M24	2
12	503010762	DIN985-M10	nut M10	16
13	702340004	SL140.00.109	lower linkage pin	2
14	508050054	GB91-2.5X12	cotter pin/ r clip	1
15-1	702190003	FMN120.00.103	pin rod 120	1
15-2	702200001	FMN120.00.103a	pin rod 150	1
15-3	702190033	FMN120.00.103b	pin rod 180	1
16	501011128	GB5783-M12X40	screw bolt M12	2
17-1	702190004	FMN120.00.105	(L=635) backstay a-frame 120	2
17-2	702200002	FMN120.00.105a	(L=728) backstay a-frame 150	2
17-3	702210001	FMN120.00.105b	(L=838) backstay a-frame 180	2
18	501010762	GB5782-M12X90	half thread bolt for a frame M12	1

8. PARTS LIST (Continued)

Dia No.	Number	Part Number	Part Description	Qty
19	700920091	EF100.00.101	spacer bush for a frame	2
20	702190005	FMN120.00.106	a frame bracket	2
21	702190001	FMN120.00.101	spacer bush	26
22	702190002	FMN120.00.102	rear fender/tooth	27
23	802110010	FM120.00.014A	small double groove belt pulley	1
24	702110078	FM120.00.112	top a-frame bracket	1
25	501011113	GB5783-M10X30	screw bolt M10	14
26	506010037	GB96.1-12	plain washer 12	2
27	503010763	DIN985-M12	lock nut 12	7
28	802110029	FM120.00.018	wheel assembly	4
29	501011138	GB5783-M12X110	screw bolt M12	4
30	506010057	GB97.1-12	plain washer 12	7
31	802110001	FM120.00.011	wheel fork	4
32	802190008	FMN120.00.011	wheel frame (120/150/180)	2
33	702170001	FMR120.00.115	(H=6) regulating spacer	4
33	702170002	FMR120.00.115a	(H=12) regulating spacer	4
33	702170003	FMR120.00.115b	(H=32) regulating spacer	4
34	702110091	FM120-00-125	spring washer/spacer	4
35	700080010	200.56.011	lockpin linch pin	4
36	509010008	GB1152-M8X1	Grease point M8	4
37	802110007	FM120.00.013A	small single groove belt pulley	2
38	702110103	FM120.00.198	M24X1.5X18 lock nut	3
39	501011087	GB5783-M6X12	grease point M6	3
40-1	514020002	B1549	belt (120)	2
40-2	514020003	B1753	belt (150)	2
40-3	514020004	B1930	belt (180)	2

8. PARTS LIST (Continued)

Dia No.	Number	Part Number	Part Description	Qty
41	802110004	FM120.00.012A	large double groove drive belt pulley	1
42	505020998	GB85-M12X60	bolt M12	1
43	503010047	GB6170-M12	nut M12	1
44	501040584	GB12-M16X45	bolt M16	4
49	501011114	GB5783-M10X35	screw bolt M10	2
50	501011098	GB5783-M8X16	screw bolt	8
51	506030035	GB93-8	spring washer	8
52	506010055	GB97.1-8	plain gasket	4
53	703400008	FM120.00.199	PTO transmission shaft cover	1
54	506010036	GB96.1-10	plain washer 10	6
55	506030036	GB93-10	spring washer 10	6
56	501010753	GB5782-M10X90	half thread bolt M10	6
57-1	702110087	FM120.00.121-L	left belt pulley cover (120)	1
57-2	702110088	FM120.00.121a-L	left belt pulley cover (150)	1
57-3	702110089	FM120.00.121b-L	left belt pulley cover (180)	1
58	802110093	FM120.01.001	transmission gearbox	1
59	503010765	DIN985-M16	nut 16	4
60	506010059	GB97.1-16	plain washer 16	4
61	702110073	FM120.00.108	transmission gearbox pad/plate	1
62	506010035	GB96.1-8	plain washer 8	4
63-1	702110114	FM120.00.121-R	right belt pulley cover (120)	1
63-2	702110115	FM120.00.121a-R	right belt pulley cover (150)	1
63-3	702110116	FM120.00.121b-R	right belt pulley cover (180)	1
64	702110077	FM120.00.110-2	rubber grease cover	3
65	702110090	FM120.00.222	plug	2
66	702110086	FM120.00.120-1	nylon cover	8

9. PARTS DIAGRAM 2 - #6 FM120.00.012 breakdown

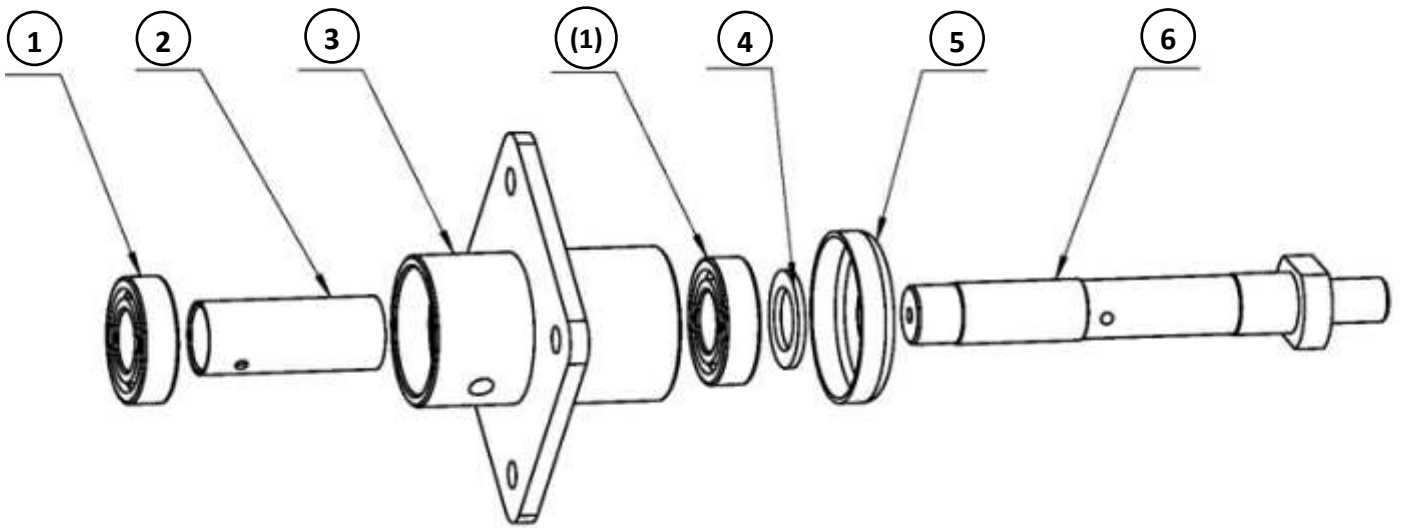

9. PARTS LIST 2 - #6 FM120.00.012 breakdown

Dia No.	Number	Part Number	Part Description	Qty
1	511022103	GB276-6205-Z	deep groove ball bearing 6205	2
2	702110019	FM120.00.114	spacer bush	1
3	802190011	FMN120.00.020	blade seat	1
4	702110022	FM120.00.126	gasket	1
5	702110021	FM120.00.117	shield	1
6	802110020	FM120.00.116	blade shaft/ spindle	1

10. PARTS DIAGRAM 3 - #28 FM120.00.018 breakdown

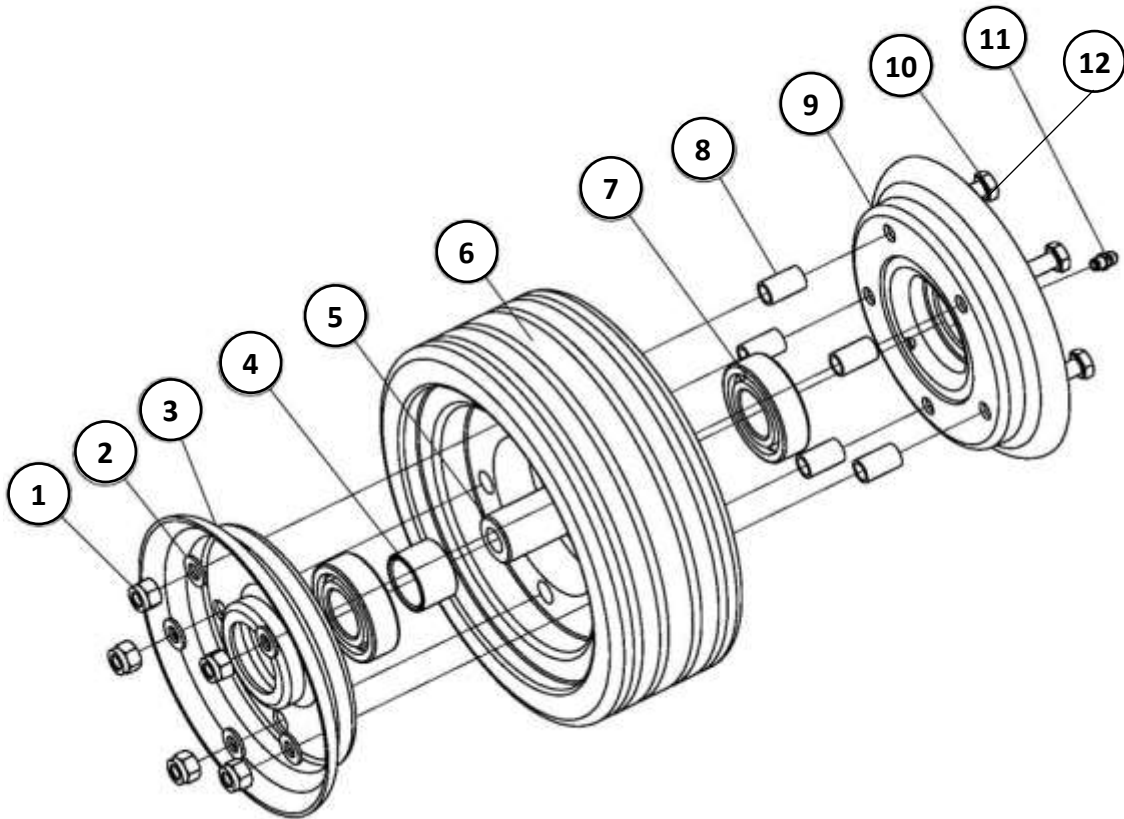

10. PARTS LIST 3 - #28 FM120.00.018 breakdown

Dia No.	Number	Part Number	Part Description	Qty
1	503010761	DIN985-M8	nut	5
2	506010055	GB97.1-8	plain gasket	5
3	702110030	FM120.00.161	steel ring	1
4	702110034	FM120.00.165	spacer bush	1
5	702110035	FM120.00.166	sleeve	1
6	702110033	FM120.00.164	rubber wheel	1
7	511022103	GB276-6205-Z	deep groove ball bearing	2
8	702110032	FM120.00.162	bushing	5
9	702110031	FM120.00.161a	steel ring	1
10	501011102	GB5783-M8X35	bolt	5
11	509010007	GB1152-M6	grease point	1
12	506010055	GB97.1-8	plain gasket	5

NOTES

PTO SHAFT RESIZING

Safety: Ensure tractor & machine is stopped & keys out of ignition before carrying out any work. If you are not confident in carrying out the work consult your local supplier or mechanic.

Most PTO driven implements are supplied with a standard sized PTO shaft. As all tractors vary this often means cutting it down to size. Always replace worn or damaged PTO shafts.

Attach the machine to the tractor without the PTO shaft, raise the linkage so the PTO shaft is level/horizontal. Measure the length between tractor PTO and the machine's shaft. If the compressed (closed) PTO shaft length exceeds the one measured here then the driveline will need to be cut.

1. PTO length adjustment, first remove PTO shaft shielding.

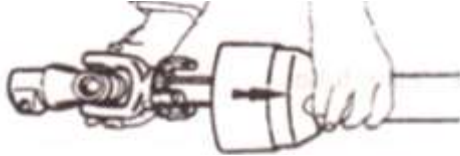

2. Shorten the driveline tubes to proper equal lengths.

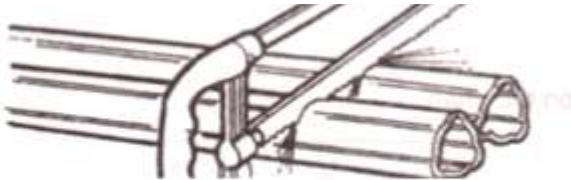

3. Tidy edges of the drive tube with a file and clean all fillings from the tubes.



4. Shorten the equally long guard tubes to the same length as the driveline tubes.



5. Grease the internal driveline tube.



6. Fit the guard on the shaft.

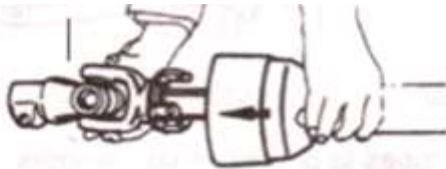

7. Make sure that the length allows for at least 16cm (6 inches) of overlap.



WINTON PRODUCT WARRANTY

We always strive to create great products, but when something does go wrong we have a strong network of resellers on hand throughout the UK to help out.

Warranty Claims

Before you get in touch here are 5 pieces of information your Winton reseller will need to progress your claim:

- Your invoice/order details - to include date of purchase
- Machine model number
- Machine serial number
- Details of the fault
- Images/videos of the fault

The Terms & Conditions

All products purchased as new are covered under our 12 month warranty from the date of purchase. During this period Winton will repair or replace defective parts free of charge. This warranty is given on the proviso that the product has been used and maintained according to the Owner's Manual.

Warranty is carried out on a return to reseller / manufacturer basis and excludes any labour or delivery / collection costs.

Exclusions

- Wearing parts are excluded; including but not limited to blades, belts and bearings.
- Modification of the product in any way will cease the manufacturers warranty.
- The machine is warranted for one year to the original purchaser, resale within the period will cease the warranty.
- Damage in transit is not covered. Claims will need to be made through the courier or your Winton reseller directly.
- Compensation for down-time, labour or loss of earnings is not covered by the warranty.
- No warranty extension will be granted for replacement parts fitted.
- Damage caused by continued use of a faulty machine will not be covered.

Your **Winton** reseller will provide their own terms and conditions upon purchase, consult this for any additional queries.

TROUBLE SHOOTING

Safety: Ensure tractor and machine is stopped & keys out of ignition before set-up/maintenance.

WFM Problem	Solution
Belt Slipping	<p>Clean the mower deck.</p> <p>Check that belts are not contaminated by oil or grease.</p> <p>Replace belts.</p> <p>Cut down any overgrown areas before using a finishing mower.</p>
Poor cutting	<p>Mow at 540 PTO rpm, check PTO speed & tractor power output.</p> <p>Slow the working speed.</p> <p>Change into a lower gear on the tractor.</p> <p>Tension/replace belts.</p> <p>Check blades, replace if damaged or worn.</p> <p>Raise the cutting height.</p> <p>Adjust tractor top linkage arm to level machine & allow float.</p>
Excessive vibration	<p>Ensure tractor PTO is set to 540 rpm.</p> <p>Replace blades if worn or damaged.</p> <p>Tension/replace belts.</p> <p>Remove belt guard and clean debris from belt area.</p> <p>Check PTO shaft for damage and replace.</p>
Gearbox noisy	<p>Check oil level and top up if required.</p> <p>Extract the oil/debris and replace with new oil.</p>
Blades scalping	<p>Raise the cutting height.</p> <p>Change mowing pattern/route.</p> <p>Reduce speed when turning.</p>
Tractor loaded down by mower	<p>Mow at 540 PTO rpm.</p> <p>Change into a lower gear on the tractor.</p> <p>Cut down any overgrown areas before using a finishing mower.</p> <p>Clean off the mower.</p> <p>Check power output on your tractor.</p>

Always consult your **Winton** dealer if you have any questions about your machine.



W Winton

www.wintonmachinery.co.uk