

WINTON TIPPING TRAILER WTL SERIES



OWNERS MANUAL

PLEASE READ THIS MANUAL BEFORE OPERATING THE TRAILER

Congratulations on purchasing your new **Winton** trailer!

Before you get started, we have provided a helpful space to jot down a few important details about your new Winton machine.

Model Number: **WTL15**

Serial Number:

Date of purchase:

Factory Reference: TL1000

This manual should be considered a permanent part of this machine and should remain with it even if the machine is subsequently sold.

Winton continually seeks advancements in its product design and quality. Therefore, while this manual contains the most current product information available at the time of printing, there may be minor discrepancies between your machine and this manual.

If you have any questions concerning this manual, please consult your local dealer.

General Safety Information

Ensure all potential operators read this manual thoroughly before using the machine.

Safety: Ensure tractor and machine is stopped & keys out of ignition before set-up/maintenance.

Safety: Failure to follow good safety standards could result in severe injury or even death.

Misuse: This machine is designed for use with compact tractors, and should be used only for the indicated purpose. Winton does not take responsibility if the machine is used for any other purpose. Children must not operate the machine under any circumstance.

Modification: Do not modify equipment in any way. This may impair the operation and overall safety of the machine.

Tractor requirements: Use only with compact tractors within power range specified.

Misuse transport: Do not use machinery to transport personnel or livestock.

Condition: For the safety of personnel and optimum performance of the machine, you should check the condition of the machine and the tractor before starting. Before use check all nuts and bolts are tight.

Spatial awareness: Always check the operating area is safe before starting machinery.

Operator clothing: The operator should not wear loose clothing while operating machinery.

Safety wear: Always use appropriate ear protection when running a tractor and machinery. Ensure you are wearing protective gloves when servicing and using machinery.

Bystander safety: Ensure bystanders keep away from the machine when it is in use. Do not touch moving parts when the machine is at work.

Public places: When travelling on the road/public places, always keep the PTO turned off.

Maintenance: Always keep the machine maintained and in a good state. Where necessary, repair or replace any defective parts. Do not modify the machine.

Sharp objects: Pay attention to the sharp/pointed parts while servicing the machine.

Safety guards: All protective parts should be in good condition before operating machinery.

Safety signs/stickers: Keep all safety signs clean and legible. Replace any which are missing or illegible. If a component with safety sign/(s) is replaced, make sure new safety sign/(s) are attached in the same locations.

Operating speeds: Machinery and PTO should be operated at the recommended speed at all times.

Safety awareness: Good safety requires that you familiarise yourself with various safety signs, the type of warning and the area, or particular function related to that area.

Alertness: Never consume alcohol or drugs these can hinder alertness/coordination. Consult your doctor about using this machine while taking prescription medications.

General Safety Information (continued)

Machinery Pre-Use Checks

On receipt of your new Winton machine and again within the first 4 hours of use, or the 'shake in' period as we like to call it, we always recommend checking over the machine.

- Check all bolts, nuts and screws are tight on the unit.
- Tighten/check any bolts and nuts securing blades.
- If your machine has belts check the tension and adjust if required.
- Apply grease to grease points if necessary.
- Remove support/storage stands before operating machinery.
- Check oil levels and top up if needed.

Tractor Pre-Use Checks

Check that the machine is properly attached to the tractor. Ensure that secure pins are used on the linkage mounting pins.

Be sure to add extra weights to the front of the tractor or add wheel weights if required.

Install and secure all safety guards, doors and covers before starting.

Bystanders should leave the immediate area before connecting the drive from the tractor.

Running/Operating Checks

- Always keep the PTO output from the tractor at **540 RPM** when running machinery.
- Never use machinery at excessive speeds.

Post-Use Regular Checks

Check blades, belts and wearing parts. Be sure they are not damaged and blades swing freely in their mount. Repair or replace as required.

Clean machinery and check for/clear any entangled material which may have got stuck around any rotating parts.

Contents

	Pg.
General Safety information	1-2
1. Dimensions and Specifications	4
2. Installation & Set Up	5
3. Trailer Usage	6
4. Hydraulics & Safety	7
5. Removing Panels	8
6. Servicing & Maintenance	9
7. Parts Diagram/List 1	10
8. Parts Diagram/List 2 Stand	11
9. Parts Diagram/List 3 Wheel Axle	12
10. Parts Diagram/List 4 Hand Brake	13
11. Winton Product Warranty	14
12. Troubleshooting	15

1. DIMENSIONS & SPECIFICATIONS

Model	WTL15
Weight	250kg
Capacity	1,500kg
Recommended Tractor HP	14-40hp
Internal Width	120cm
Internal Length	180cm
Internal Height	35cm
External Width	130cm
External Length	282cm
External Height	105cm
Linkage Type	Pin Hitch
Number of Wheels	2
Standard Tyre Size	225/55B12
Number of Hydraulic Fittings Required	1 Single Spool
Hydraulic Fitting Size	1/2 Inch BSP (Male)

*All specifications are subject to change without notice.

2. INSTALLATION & SET UP

Safety: Ensure tractor and machine is stopped & keys out of ignition before set-up/maintenance.

Safety: Before attaching/detaching machinery ensure the hydraulic lift system is in a neutral position.

You will need:

Your tractor with suitable hydraulics outlets & towing draw bar to attach the trailer's pin hitch.

Attaching The Trailer

Start by finding a flat piece of ground. Ensure the handbrake **(1)** is engaged on the trailer. The hand brake is located near the towing frame and can be engaged by pressing the button on the top and ensuring the handle is upright. Similarly to dis-engage the handbrake the button should be pressed and the moving the handle in to a horizontal position.

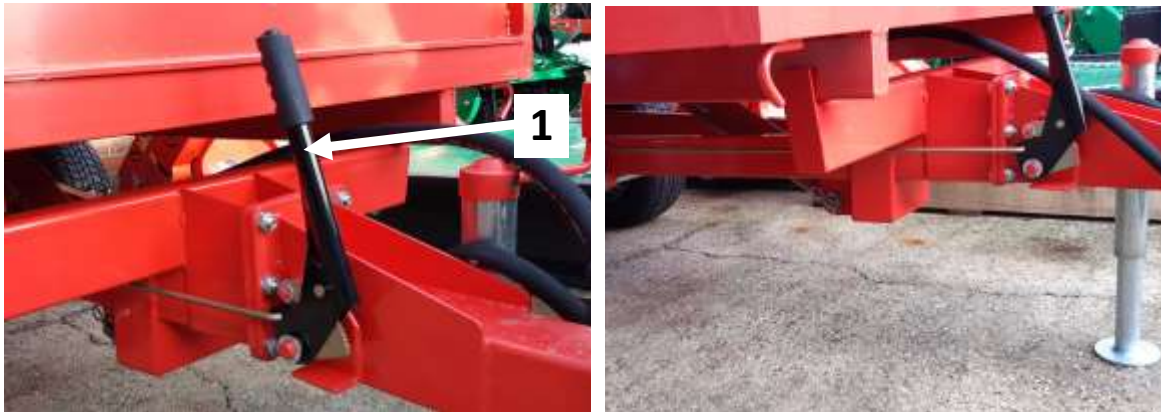

Align the tractor's rear drawbar to the pin hitch **(2)** on the trailer. Then raise or lower the trailer hitch using the stand **(3)**. The handle can be used to wind the trailer up so the trailer and tractor hitching points are aligned. Then insert the tractor pin through the drawbar and trailer hitch to secure in place.

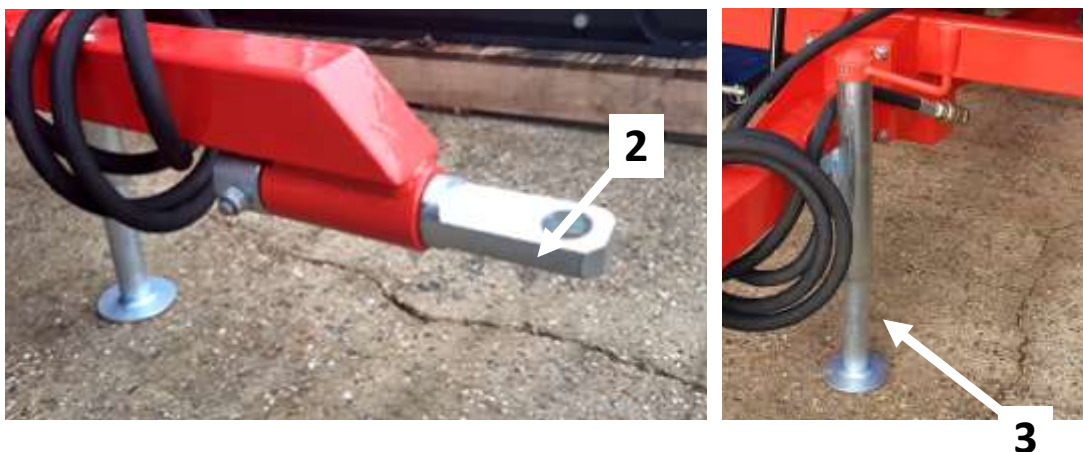

Pre-Use Checklist

- Before using the machinery, always check and adjust the tightness of all bolts, nuts and screws. Check lubrication/grease points and ensure sufficient hydraulic oil is in the tractor reservoir. Also check all protective guards are in place.

3. TRAILER USAGE

Proper Usage

This trailer is designed for agricultural use with a compact tractor. It is not intended or specified for road use. Trailer tyres are not designed for road speeds or use.

Do not exceed 20 mph (32 kph) when towing the trailer and always reduce speed on rough, uneven and slippery surfaces. Avoid making any sudden stops when towing.

Make sure the controls are operated only when seated in the tractor's seat. Always ensure the operating area is clear of bystanders and obstructions when using the trailer. Ensure persons do not stand, walk or work underneath the trailer when raised.

Proper Loading

The trailer is designed to bear a maximum of 1.5tn of weight, please do not overload. Be mindful of the type of load on the trailer. Loose loads should be secured. All loads, especially liquid loads, should be moved slowly with smooth movements when cornering, accelerating or braking.

Never carry people in the trailer or on any portion of the trailer or trailer attachments.

Proper Use On Hills & Cornering

When working on slopes always set brakes on the tractor and trailer. Shift down before starting up or down a hill with a heavy load.

Turn into corners or ascend/descend any slopes or hills at a low speed. Ensure that steering is made at a gradual angle rather than sharp turns to prevent the load from tipping.

Always make sure that at least 20% of the tractor's weight is on the tractor's front wheels for safe operation and manoeuvrability.

Do not use on steep slopes, especially when loaded.

4. HYDRAULICS & SAFETY

Safety: Ensure tractor and machine is stopped & keys out of ignition before set-up/maintenance.

Fitting Hydraulics

Ensure your tractor has sufficient hydraulic oil in the reservoir before attaching hydraulics pipes. Consult your tractor manual for more information on the hydraulic tank and checking oil levels. Your manual will also advise on the grade of hydraulic oil to use. Type 32 hydraulic oil is a well known grade for compact tractors.

There is one hydraulic fitting (**1**) which needs to be coupled, this is 1/2 Inch BSP (male) which is common for most compact tractors. Converters are also widely available if your tractor does not suit this size.

First, pull the collar back on the tractor female hydraulic fitting. Then push the male trailer fitting in to the socket and release the collar to secure in to place.

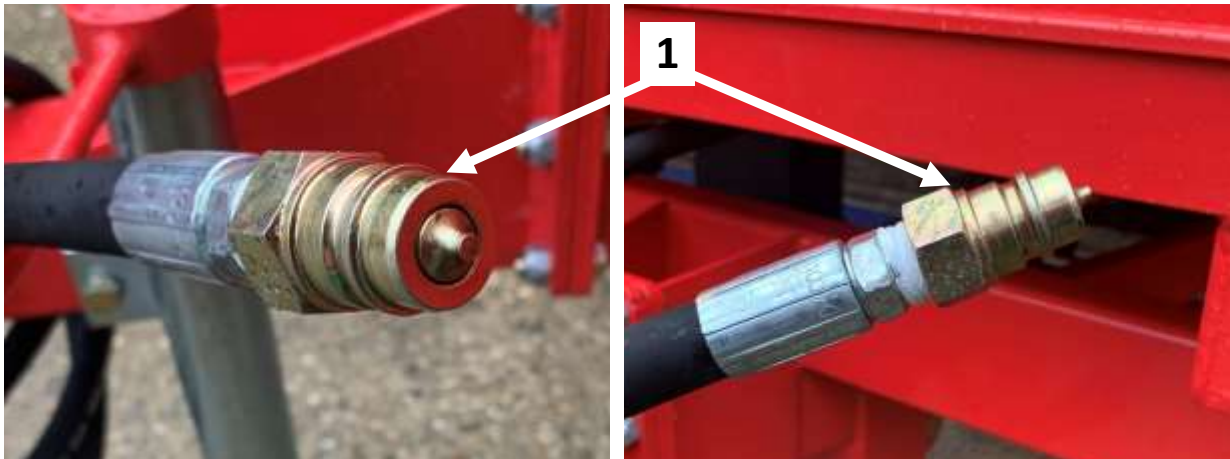

Hydraulic Safety

Always make sure the hydraulic system and all components are kept in good condition and clean. Before applying any hydraulic pressure to the system, make sure all components are tight and that lines, hoses and couplings are not damaged. Replace any worn, cut, flattened or crimped hoses and lines straight away.

Do not attempt any makeshift repairs to the hydraulic lines, fittings or hoses by using tapes or clamps. The hydraulic system operates under high pressure. Such repair may cause hazardous and unsafe conditions.

Always wear proper hand and eye protection when working with high pressure hydraulics. Use a piece of wood or cardboard as a backstop instead of hands to isolate and identify any leaks.

If injured by a concentrated high pressure stream of hydraulic fluid, seek medical attention immediately. Serious infection or toxic reaction can develop from hydraulic fluid on the skin.

5. REMOVING PANELS

Opening & Removing Panels

The sides and rear panels can be opened and folded down for easy loading and unloading. Open the rear tail gate when using the tipping function for easy offloading.

The securing latches (**1**) need to be pulled up and twisted horizontally to allow the panel to release. There are 4 latches on the side panels and 2 on the rear panel.

To remove the panels completely the panels should be folded down as above then slid to the side to release from the hinge brackets. This will need an extra pair of hands, especially on the side panels due to the weight.



6. SERVICING & MAINTENANCE

Grease Type	Multi-purpose lithium based grease
Pivot Points Grease Frequency	Check every 4-8 hours (top up if required)
Hydraulic Oil Type/Level	Check daily/10hrs (see tractor manual)
Hydraulic Oil Filter	See tractor manual for filter change
Trailer Tyre Pressure	Approx. 20-30psi (dependent on condition)
Tyre Pressure Check Frequency	Check weekly/50hrs which ever is first
Hydraulic connectors & RAM	Check daily/10hrs which ever is first

Lubrication & Maintenance

Lower the trailer to the ground and relieve pressure in trailer hydraulic lines prior to performing any service or maintenance operations on the tractor or trailer. When checking hydraulic system oil level, the tractor should be on the ground and the trailer emptied & fully retracted (all cylinders in retracted position).

Check the tractor hydraulic system as outlined in the tractor operator's manual.

Inspect hydraulic hoses, connections, control valve and cylinders for evidence of leakage regularly.

Grease all trailer pivot points daily (10 hours).

Other Maintenance

Oils: Ensure oil levels are checked and topped up when needed.

Cleaning: Ensure the machine is cleaned of mud and grass. Remove debris from any moving parts.

Paintwork: Re-coat any damaged paintwork to prevent corrosion.

Wheels: Check the condition of all wheels and replace if any are broken or damaged.

Storage: Store the machine in a dry, level area with the hand brake applied. Chock the wheels and support the frame if necessary.

The periods recommended are based on normal operating conditions. Severe or unusual conditions may require more frequent maintenance.

7.

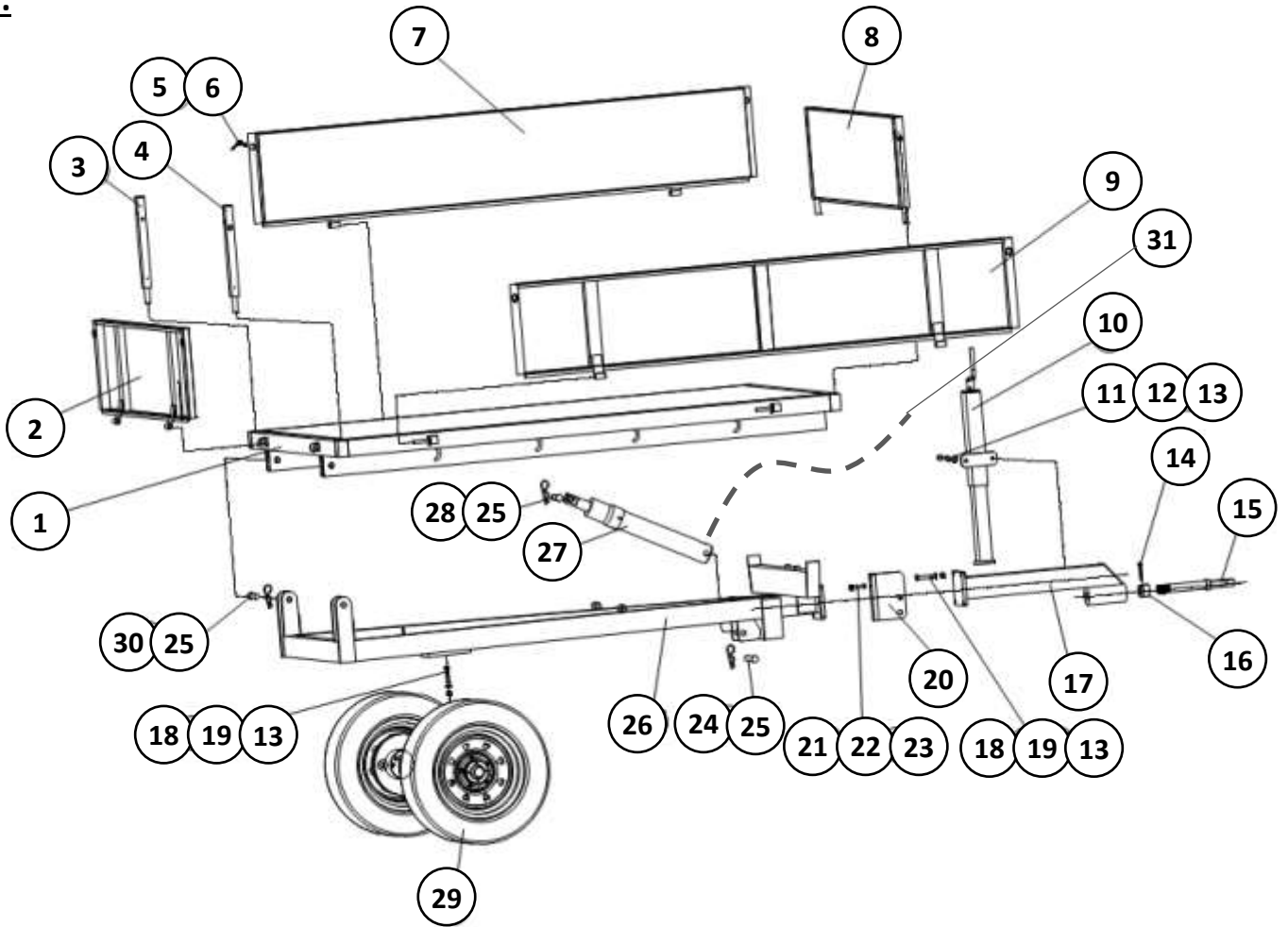

Dia	Part Number	Part Description	Qty
1	TR100.021	Bottom Panel	1
2	TR100.020	Rear Panel	1
3	TR100.022	Left Pillar	1
4	TR100.019	Right Pillar	1
5	TR100.017	Lock Mechanism	6
6	GB/T6170-00	Nut M8	6
7	TR100.023	Left Panel	1
8	TR100.016	Front Panel	1
9	TR100.018	Right Panel	1
10	TR100.002	Jockey Stand	1
11	GB/T5783-00	Bolt M12x40	2
12	GB/T93-87	Spring Washer	6
13	GB/T97.1-02	Plain Washer	10
14	GB/T91-00	Cotter Pin	1
15	TR100.101	Pin Hitch	1

Dia	Part Number	Part Description	Qty
16	GB/T6178-86	Nut M30	1
17	TR100.010	Drawbar	1
18	GB/T5782-00	Bolt M12x50	8
19	GB/T889.1-00	Locknut M12	8
20	TR100.012	Brake Fixing Plate	1
21	GB/T5783-00	Bolt M10x30	2
22	GB/T93-87	Spring Washer	2
23	GB/T97.1-02	Plain Washer	2
24	TR100.109	Cylinder Pin	1
25	TR100.107	R Clip	4
26	TR100.015	Chassis	1
27	TR100.014	Hydraulic Ram	1
28	TR100.108	Pin	1
29	TR100.041	Wheel	2
30	TR100.113	Pin	2
31	TLHOSE	Hydraulic Hose	1

8. Parts Diagram/List 2 - #10 TR100.002 Stand/leg breakdown

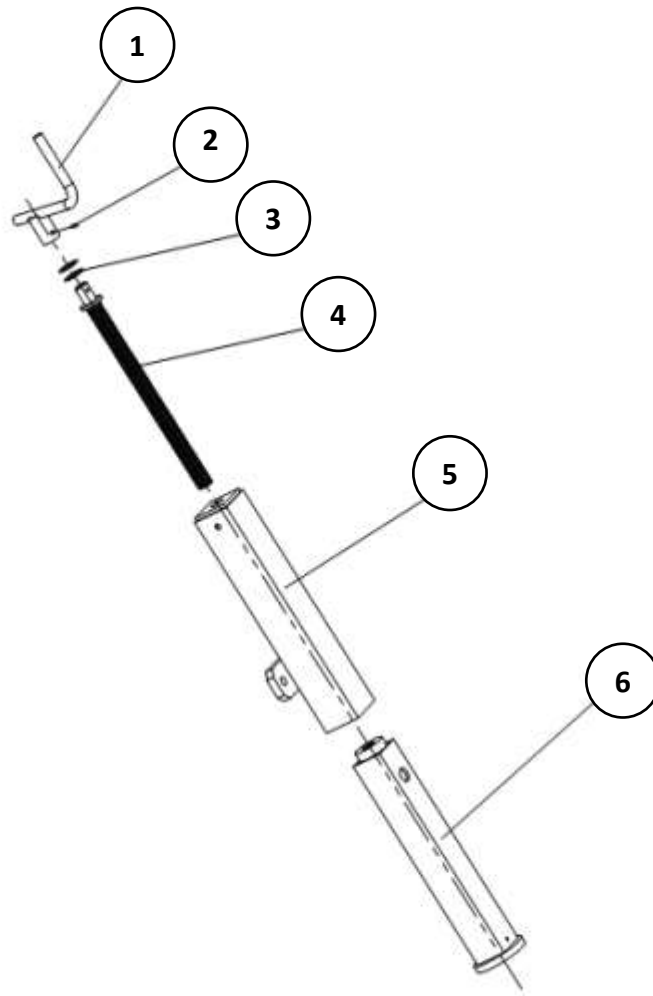

Dia No.	Part Number	Part Description	Qty
1	TR100.038	Handle	1
2	GB/T879.1-00	Pin 5x26	1
3	TR100.300	Washer	2
4	TR100.036	Screw Mechanism	1
5	TR100.035	Screw Mechanism Casing	1
6	TR100.037	Screw Inner Pipe Mechanism	1

9. Parts Diagram/List 3 - Wheel axle breakdown

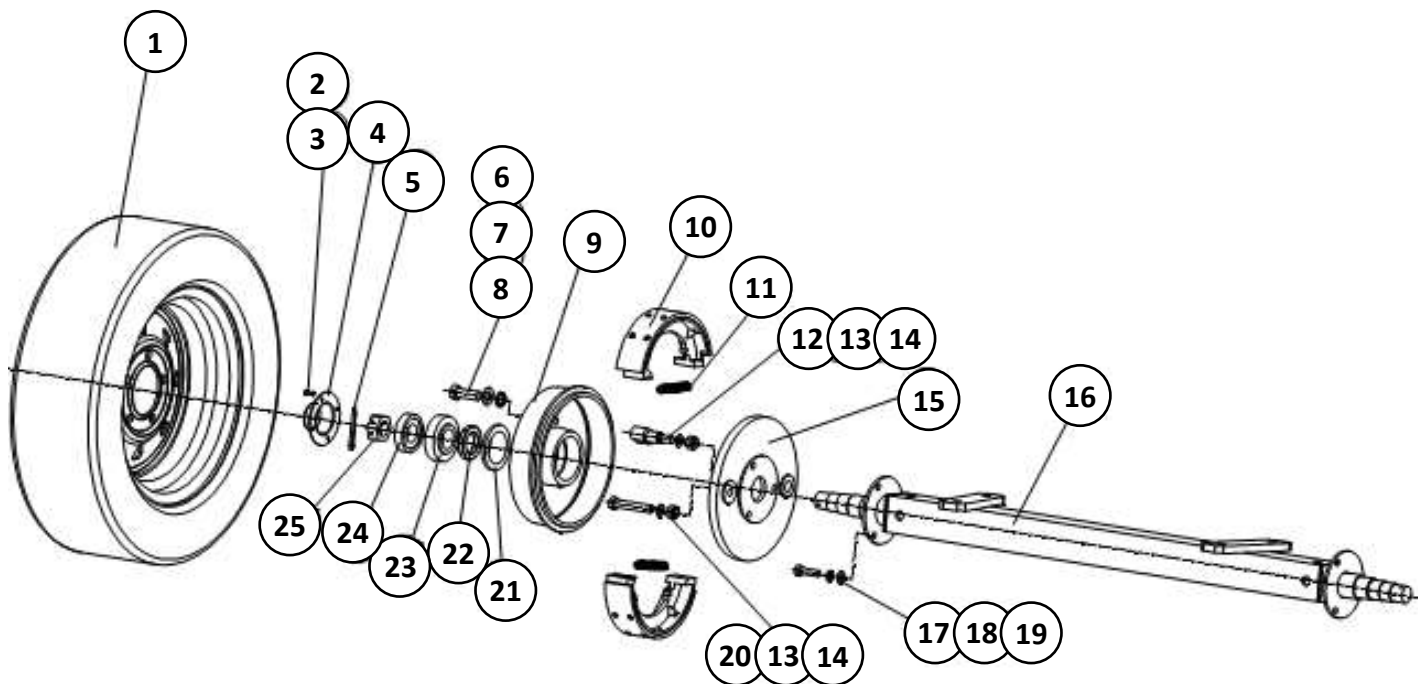

Dia	Part Number	Part Description	Qty
1	TR100.041	Wheel	2
2	GB/T65-00	Screw M4x10	8
3	GB/T97.1-02	Plain Washer	8
4	TR100.353	Wheel Bearing Cover	2
5	GB/T91-00	Cotter Pin	2
6	GB/T5783-00	Bolt M14x35	10
7	GB/T93-87	Spring Washer	10
8	GB/T97.1-02	Plain Washer	10
9	TR100.355	Brake Drum	2
10	TR100.350	Brake Shoe	4
11	TR100.351	Spring	4
12	TR100.354	Brake Shaft	2
13	GB/T97.1-02	Plain Washer	4

Dia	Part Number	Part Description	Qty
14	GB/T889.1-00	Hex Nut M12	4
15	TR100.356	Brake Drum Plate	2
16	TR100.040	Axle Weldment	1
17	GB/T5783-00	Bolt M10x35	6
18	GB/T97.1-02	Plain Washer	6
19	GB/T889.1-00	Lock Nut M10	6
20	GB/T5782-00	Bolt M12x70	2
21	HG4-692-67	Seal 72x55x8	2
22	TR100.352	Bearing Retainer Ring	2
23	GB/T297-94	Bearing 30207	2
24	GB/T297-94	Bearing 30206	2
25	GB/T6178-86	Nut M27	2

10. Parts Diagram/List 4 - Hand brake breakdown

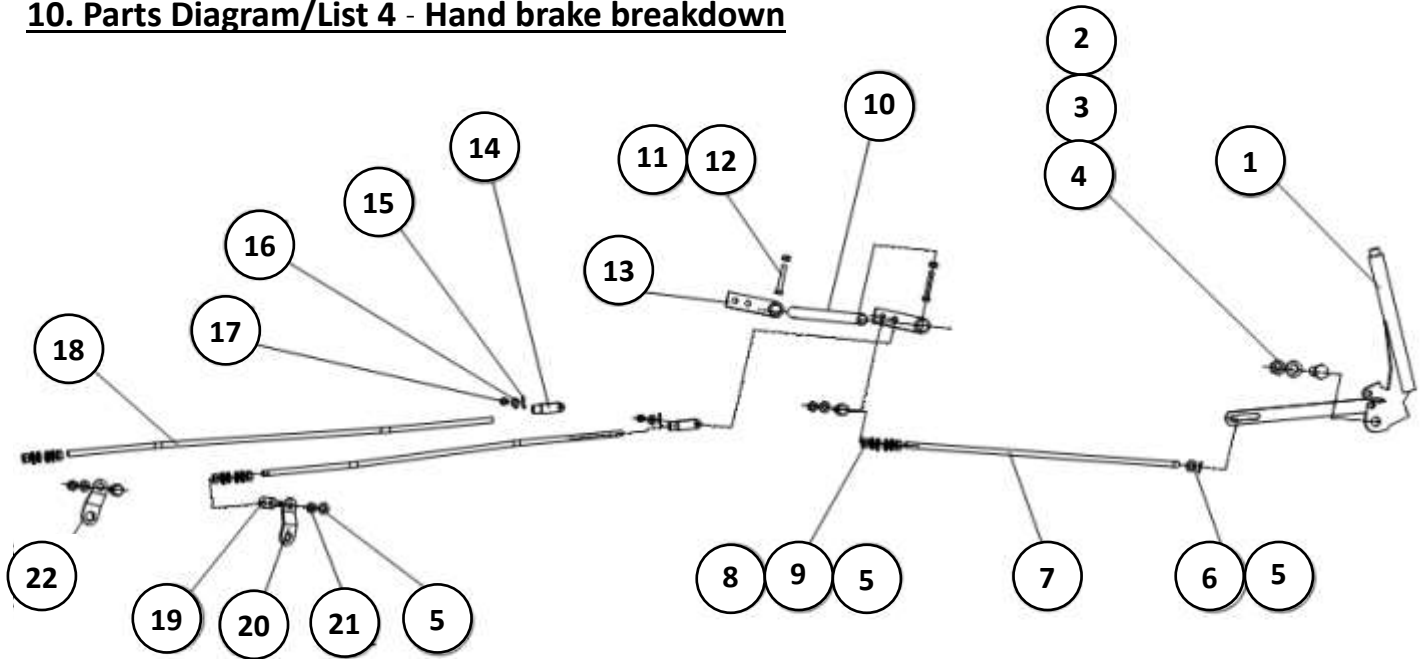

Dia No.	Part Number	Part Description	Qty
1	TR100.011	Hand Brake	1
2	GB/T5783-00	Bolt M16x50	1
3	GB/T97.1-02	Plain Washer	1
4	GB/T889.1-00	Hex Nut	1
5	GB/T97.1-02	Plain Washer	10
6	GB/T91-00	Cotter Pin	1
7	TR100.110	Front Brake Rod	1
8	GB/T6170-00	Nut M10	9
9	GB/T93-87	Spring Washer	6
10	TR100.105	Brake Shaft	1
11	GB/T5782-00	Bolt M8x40	2
12	GB/T5782-00	Hex Nut M8	2
13	TR100.013	Rod Connector	2
14	TR100.104	Linkage Fork	2
15	GB/T91-00	Cotter Pin	2
16	GB/T97.1-02	Plain Washer	2
17	TR100.112	Pin	2
18	TR100.111	Linkage Rod	2
19	TR100.106	Linkage	3
20	TR100.103	Right Linkage Plate	1
21	GB/T889.1-00	Hex Nut M10	3
22	TR100.102	Left Linkage Plate	1

11. WINTON PRODUCT WARRANTY

We always strive to create great products, but when something does go wrong we have a strong network of resellers on hand throughout the UK to help out.

Warranty Claims

Before you get in touch here are 5 pieces of information your Winton reseller will need to progress your claim:

- Your invoice/order details - to include date of purchase
- Machine model number
- Machine serial number
- Details of the fault
- Images/videos of the fault

The Terms & Conditions

All products purchased as new are covered under our 12 month warranty from the date of purchase. During this period Winton will repair or replace defective parts free of charge. This warranty is given on the proviso that the product has been used and maintained according to the Owner's Manual.

Warranty is carried out on a return to reseller / manufacturer basis and excludes any labour or delivery / collection costs.

Exclusions

- Wearing parts are excluded; including but not limited to blades, belts and bearings.
- Modification of the product in any way will cease the manufacturers warranty.
- The machine is warranted for one year to the original purchaser, resale within the period will cease the warranty.
- Damage in transit is not covered. Claims will need to be made through the courier or your Winton reseller directly.
- Compensation for down-time, labour or loss of earnings is not covered by the warranty.
- No warranty extension will be granted for replacement parts fitted.
- Damage caused by continued use of a faulty machine will not be covered.

Your **Winton** reseller will provide their own terms and conditions upon purchase, consult this for any additional queries.

12. TROUBLE SHOOTING

Safety: Ensure tractor and machine is stopped & keys out of ignition before set-up/maintenance.

WTL Problem	Solution
Trailer Body Not Tipping	Tractor short of hydraulic oil - fill or replace as required Check hydraulic hoses & connections Check tractor hydraulic valve with other attachments
Hydraulic Oil Leak	Check seals & O rings Tighten loose connection Check hydraulic ram condition
Excessive Sound	Check nuts & bolts are tight all round Grease trailer where required

Always consult your **Winton** dealer if you have any questions about your machine.

NOTES



W Winton

www.wintonmachinery.co.uk