

WINTON HEDGE CUTTER

WAM SERIES



OWNERS MANUAL

PLEASE READ THIS MANUAL BEFORE OPERATING THE CUTTER

Congratulations on purchasing your new **Winton** cutter!

Before you get started, we have provided a helpful space to jot down a few important details about your new Winton machine.

Model Number: **WAM**

Serial Number:

Date of purchase:

Factory Reference: AM60/AM80/AM100

This manual should be considered a permanent part of this machine and should remain with it even if the machine is subsequently sold.

Winton continually seeks advancements in its product design and quality. Therefore, while this manual contains the most current product information available at the time of printing, there may be minor discrepancies between your machine and this manual.

If you have any questions concerning this manual, please consult your local dealer.

First Published: February 2020

General Safety Information

Ensure all potential operators read this manual thoroughly before using the machine.

Safety: Ensure tractor and machine is stopped & keys out of ignition before set-up/maintenance.

Safety: Failure to follow good safety standards could result in severe injury or even death.

Misuse: This machine is designed for use with compact tractors, and should be used only for the indicated purpose. Winton does not take responsibility if the machine is used for any other purpose. Children must not operate the machine under any circumstance.

Modification: Do not modify equipment in any way. This may impair the operation and overall safety of the machine.

Tractor requirements: Use only with compact tractors within power range specified.

Misuse transport: Do not use machinery to transport personnel or livestock.

Condition: For the safety of personnel and optimum performance of the machine, you should check the condition of the machine and the tractor before starting. Before use check all nuts and bolts are tight.

Spatial awareness: Always check the operating area is safe before starting machinery.

Operator clothing: The operator should not wear loose clothing while operating machinery.

Safety wear: Always use appropriate ear protection when running a tractor and machinery. Ensure you are wearing protective gloves when servicing and using machinery.

Bystander safety: Ensure bystanders keep away from the machine when it is in use. Do not touch moving parts when the machine is at work.

Public places: When travelling on the road/public places, always keep the PTO turned off.

Maintenance: Always keep the machine maintained and in a good state. Where necessary, repair or replace any defective parts. Do not modify the machine.

Sharp objects: Pay attention to the sharp/pointed parts while servicing the machine.

Safety guards: All protective parts should be in good condition before operating machinery.

Safety signs/stickers: Keep all safety signs clean and legible. Replace any which are missing or illegible. If a component with safety sign/(s) is replaced, make sure new safety sign/(s) are attached in the same locations.

Operating speeds: Machinery and PTO should be operated at the recommended speed at all times.

Safety awareness: Good safety requires that you familiarise yourself with various safety signs, the type of warning and the area, or particular function related to that area.

Alertness: Never consume alcohol or drugs these can hinder alertness/coordination. Consult your doctor about using this machine while taking prescription medications.

General Safety Information (continued)

Machinery Pre-Use Checks

On receipt of your new Winton machine and again within the first 4 hours of use, or the 'shake in' period as we like to call it, we always recommend checking over the machine.

- Check all bolts, nuts and screws are tight on the unit.
- Tighten/check any bolts and nuts securing blades.
- If your machine has belts check the tension and adjust if required.
- Apply grease to grease points if necessary.
- Remove any stands before operating.
- Check gear oil level and top up if needed. Do not overfill.

Tractor Pre-Use Checks

Check that the machine is properly attached to the tractor. Ensure that secure pins are used on the linkage mounting pins.

Be sure to add extra weights to the front of the tractor or add wheel weights if required.

Check that the tractor PTO shaft turns freely and that the machines PTO drive shaft can extend easily. Grease the PTO drive shaft using the grease points.

The chain on the PTO shaft should be checked and in a good condition. The universal joints installed should be in a good state, with proper protective parts.

Before installing the PTO shaft, the tractor and machine should be stopped and remove the key.

Install and secure all safety guards, doors and covers before starting.

Bystanders should leave the immediate area before connecting the drive from the tractor.

Running/Operating Checks

- Always keep the PTO output from the tractor at **540 RPM** when running machinery.

Post-Use Regular Checks

Check blades, belts and wearing parts. Be sure they are not damaged and blades swing freely in their mount. Repair or replace as required.



Clean machinery and check for/clear any entangled material which may have got stuck around any rotating parts.

Contents

	Pg.
General Safety information	1-2
1. Dimensions and Specifications	4-5
2. Installation & Set Up	6-9
3. Lever Operation	10
4. Operating Advice	11-12
5. Cutting Height Adjustment	13
6. Safety Precautions	14-17
7. Hydraulic Oil Check & Maintenance	18-19
8. Gearbox Maintenance	20-21
9. Servicing & Maintenance	22-23
10. Parts Diagram 1 Body	24-25
11. Parts Diagram 2 Hydraulics	26-27
12. Parts Diagram 3 Controls	28-29
13. Parts Diagram 4 Arm	30-31
14. Parts Diagram 5 Cutting Head	32-34
15. PTO Shaft Resizing	35
16. Winton Product Warranty	36
17. FAQ's & Troubleshooting	37

1. DIMENSIONS & SPECIFICATIONS

Always ensure the rotor/ blades are stationary before changing direction using the hydraulic levers

Model	WAM60	WAM80	WAM100
Weight	260kg	275kg	300kg
Working Width	60cm	80cm	100cm
Blade Type			
Number Of Blades	24	32	40
Recommended Tractor HP	20-35hp	30-45hp	40-55hp
Width	120cm	120cm	120cm
Depth	55cm	55cm	55cm
Height	200cm	200cm	200cm
Oil capacity	55L	55L	55L
Cutting angle rotation	190 degrees	190 degrees	190 degrees
PTO Speed	540RPM	540RPM	540RPM
PTO Shaft Size	70-100cm	70-100cm	70-100cm
Linkage Size	Category 1	Category 1	Category 1

Always ensure the rotor/ blades are stationary before changing direction using the hydraulic levers

1. DIMENSIONS & SPECIFICATIONS (continued)

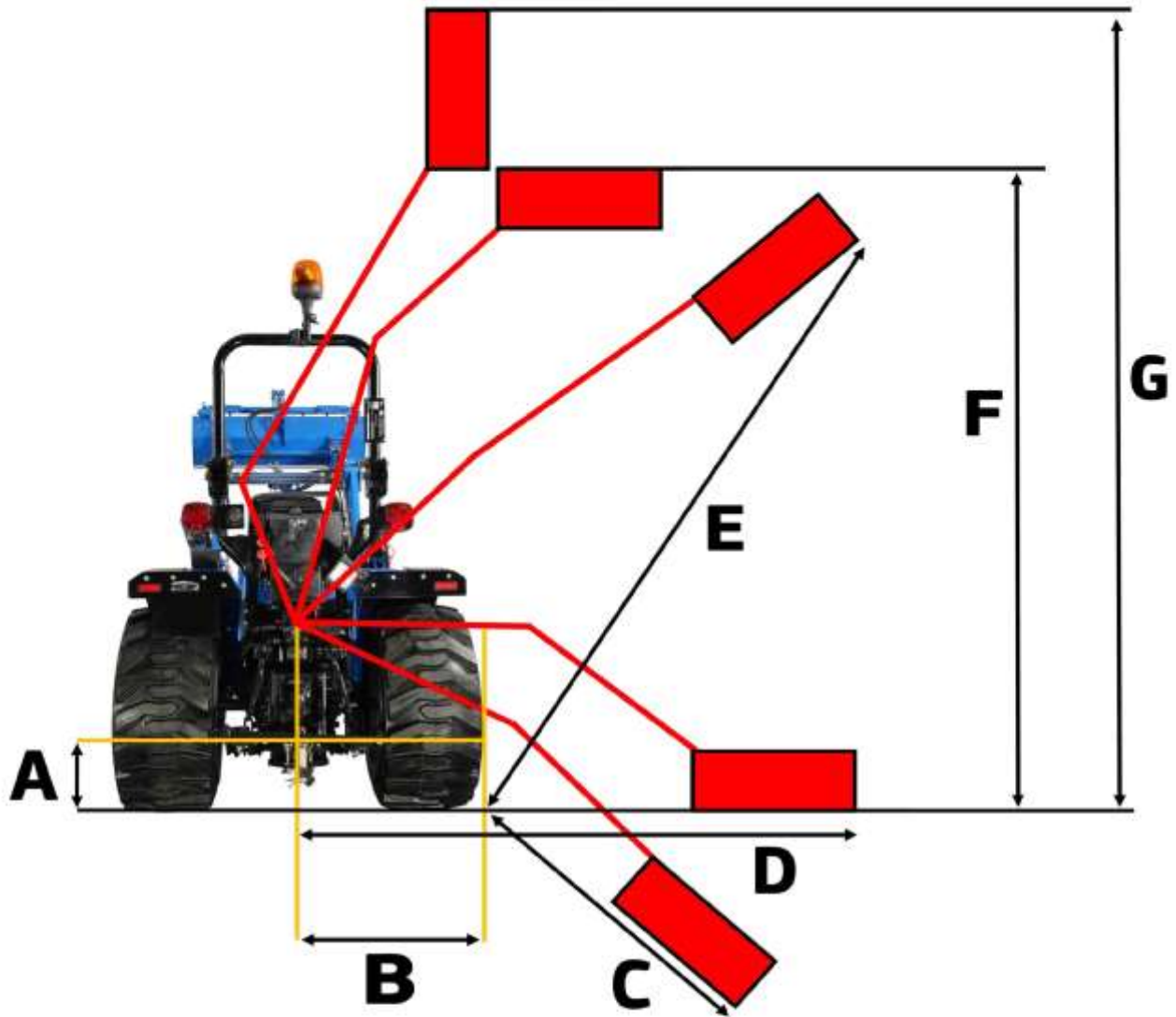

 Winton	WAM60	WAM80	WAM100
A - Lower Linkage Height	28cm	28cm	28cm
B - Top Link To Outer Wheel	70cm	70cm	70cm
C - Downwards Reach	180cm	200cm	220cm
D - Horizontal Reach	260cm	275cm	290cm
E - Diagonal Reach	280cm	310cm	340cm
F - Horizontal Height Reach	175cm	185cm	195cm
G - Vertical Height Reach	310cm	330cm	350cm

Measurements based on Solis 26 (2018 model) with industrial tyres

Please note specifications are for indication and are subject to change without notice

2. INSTALLATION & SET UP

Safety: Ensure tractor and machine is stopped & keys out of ignition before set-up/maintenance.

Safety: Before attaching/detaching machinery ensure the hydraulic lift system is in a neutral position.

Safety: Make sure the PTO drive isn't connected at any point until instructed to do so.

Attaching To The Tractor

On a flat area of ground with good access, lower the three point linkage on your tractor in line with the machine linkage and then follow these steps:

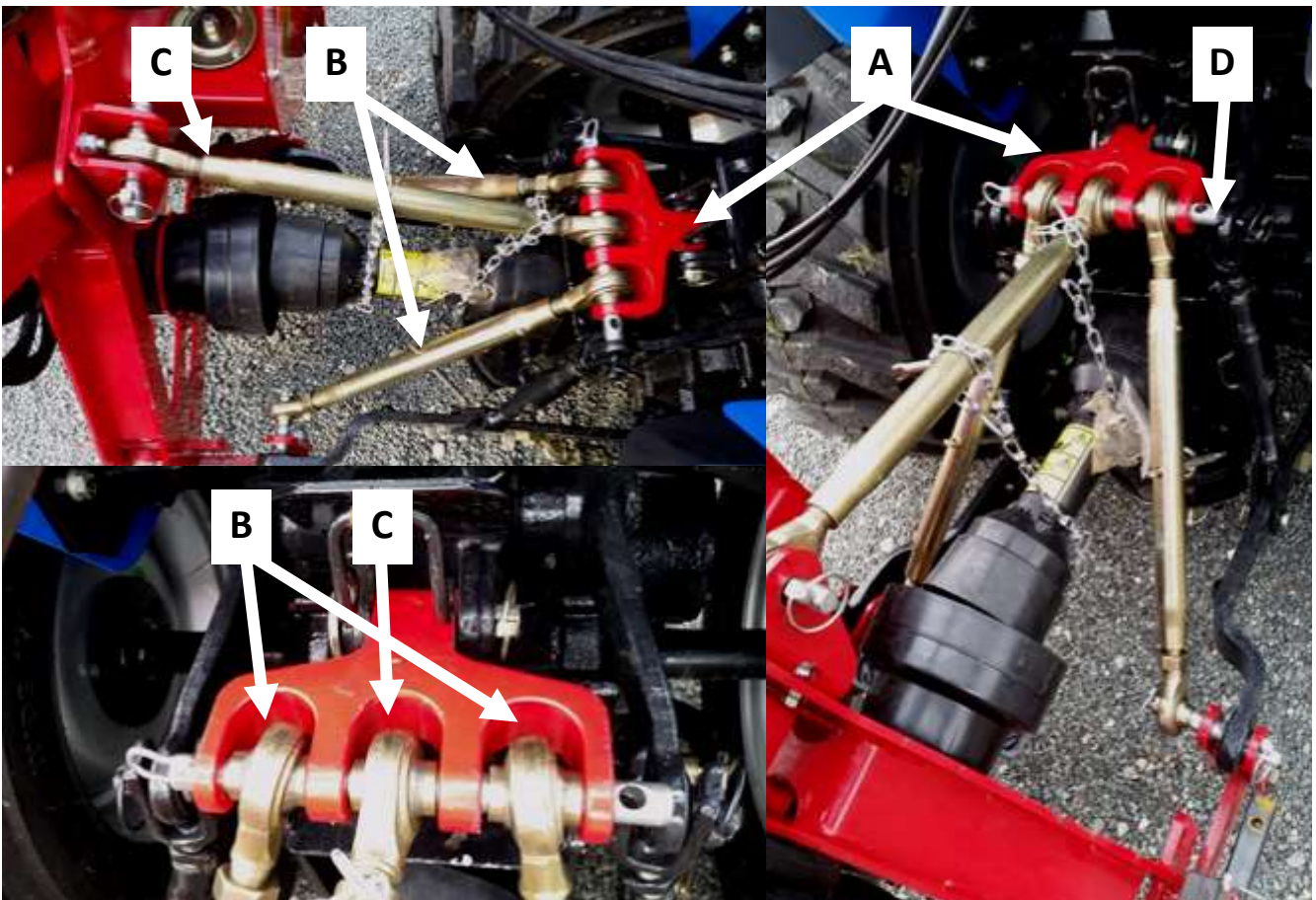

1. Attach tractor lower link arms to the frame using the lower link pins.
2. Then fit the top linkage point bracket **A** to your tractor.
3. Attach the 3x top link arms **B** & **C** to the top bracket **A** using top link pin **D**.
4. Secure arms **B** to both sides of the machines lower link points using the inside of the pins.
5. Ensure tractor lower link check chains are tight to stop the unit swinging sideways.
6. Then fit arm **C** to the top link point on the machine using the top link pin.
7. Attach the lever/controls
8. Adjust the length of arms **B** & **C** so the body & A-frame of the machine is vertical.

2. INSTALLATION & SET UP (continued)

Safety: Ensure tractor and machine is stopped & keys out of ignition before set-up/maintenance.

Safety: Before attaching/detaching machinery ensure the hydraulic lift system is in a neutral position.

Safety: Make sure the PTO drive isn't connected at any point until instructed to do so.

9. Attach PTO shaft to tractor & machine and secure chains to a fixed point as shown so the guard cannot spin (see section on PTO shaft fitting for more guidance).
10. Lift the unit using the tractor linkage & raise the stabiliser legs **E** securing with the pin.



The working speed of the machine should always be at a walking pace (approx. 2 to 5 mph) depending on the working conditions. Overgrown and tougher areas should be cut at a much slower pace for the best cut and to avoid any damage to the machine.

Check PTO shaft's grease points and apply grease if needed. Then attach the PTO drive shaft and ensure locking pin is secure on both the tractor and mower sides. Attach the chain to a secure point on the tractor/implement.

This machine should always be used on tractors with cabs or similar guards which protect the tractor and machinery operator at all times. It is advised not to operate the machine if the tractor does not have a cab or sufficient protective guards.

Make sure to check that the area is clear of bystanders or any obstructions. You should always place barriers and signage before operating. Be aware of any cuttings and debris which can be flung out from the cutting head. A tractor with a cabin should be used when hedge cutting. If the tractor has no cab make sure to create appropriate safety guards to protect the operator.

The leg stands can be removed before starting work to avoid any entanglement or impact when moving with the tractor.

Operate the machine with tractor in low range gear and the PTO delivering 540 RPM.

2. INSTALLATION & SET UP (continued)

Safety: Ensure tractor and machine is stopped & keys out of ignition before set-up/maintenance.

Safety: Before attaching/detaching machinery ensure the hydraulic lift system is in a neutral position.

Safety: Make sure the PTO drive isn't connected at any point until instructed to do so.

Detaching From The Tractor

On a flat area of ground with good access, lower the three point linkage on your tractor in line with the machine linkage and then follow these steps:

1. Close the angle of the cutting head using the hydraulic lever.
2. Then use the lever to bring the cutting arm back towards the machine.
3. Lower and secure the stabiliser legs **E** to the machine using the pins.
4. Lower machine to the floor and ensure it is stable, if not then stabilise the unit.
5. Turn off the tractor and ensure PTO drive shaft is stopped.
6. Remove the chains from the PTO and remove the PTO shaft from tractor & machine.
7. Disconnect the top link **A** and bottom link arms.
8. Remove the hedge cutter controls from their mount on the tractor.
9. Start the tractor and slowly drive off from the position, checking all connections are free.

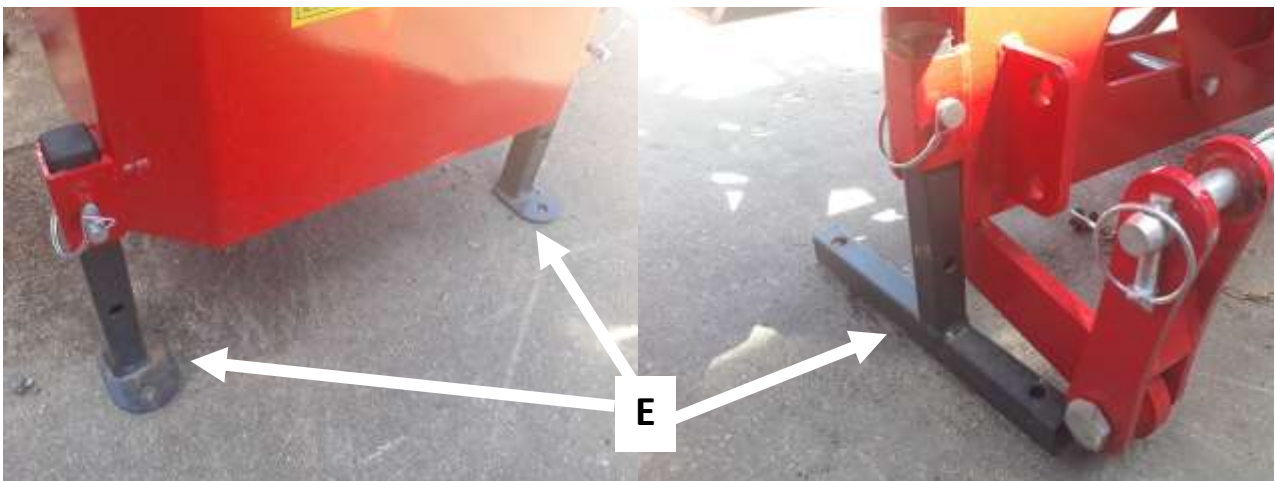

2. INSTALLATION & SET UP (continued)

Safety: Ensure tractor and machine is stopped & keys out of ignition before set-up/maintenance.

Safety: Before attaching/detaching machinery ensure the hydraulic lift system is in a neutral position.

Safety: Make sure the PTO drive isn't connected at any point until instructed to do so.

Pre-Cutting Checklist

Before starting the machine, always check and adjust the following:

- Read and understand all parts of this guide.
- Check blades are in good condition.
- Check hydraulic oil level.
- Lubricate all grease points.
- Check tightness of all bolts, nuts and screws.
- Ensure all protective guards are in place and in good condition.
- Make sure correct PPE is used e.g. helmet with visor, ear protection, steel toe shoes etc.
- Check the area is clear of bystanders or obstructions.
- Place barriers and signs before working.
- Adjust rotation of blades to suit direction of cutting.
- Adjust roller for cutting height.
- Keep hydraulic fixings tightened to prevent leaks.
- Ensure hydraulic pipes are not pinched, chafing or being stretched.
- Ensure the tractor is fitted with adequate guards/protection (e.g. a cabin) to protect the against thrown debris or parts.

3. LEVER OPERATION

The operating levers are in an easy to move block. Fix the cable controls to your tractor in a convenient place for operating. Make sure not to obstruct the entry/exit of your tractor or cab when positioning. Ensure the cables are free from tangling or catching on any moving parts.

Remember to always operate the levers smoothly to prevent any sudden or jerky movements.

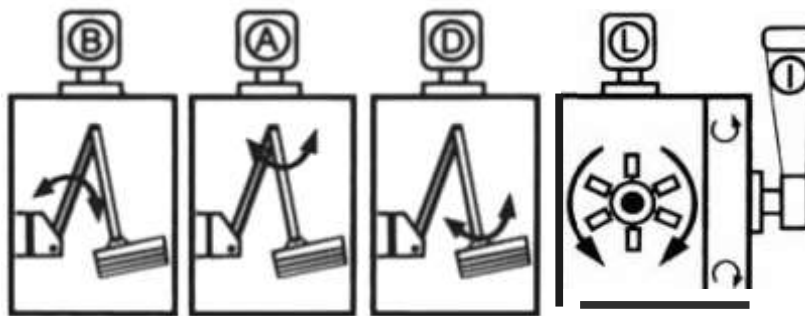

	Lever	Forward operation	Backward operation
I*	Reversal of cutting rotor direction	Rotor rotation up at the front	Rotor rotation down at the front
L*	Rotor start/stop		
B	Main arm up/down	Main arm downwards	Main arm lift upwards
A	Arm reach in/out	Reach outwards	Reach inwards
D	Cutting head angle	Angle clockwise	Angle anti-clockwise

***WARNING: Always ensure the rotor and blades are stationary before changing direction using hydraulic levers L & I.**

This can lead to a build up of pressure in the hydraulic system which may lead to leaking connectors, pipes, broken seals or even damage to the hydraulic pump.

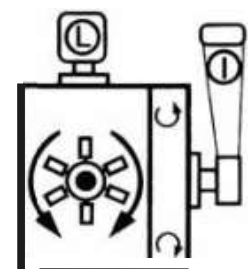

4. OPERATING ADVICE

The control levers for the hydraulic RAMs on the arms should return to the neutral position when the lever is free. This system is important in order to avoid an involuntary movements or displacements of the arms.

Using the levers and making absolutely sure that the area is clear of people and obstacles. Power the arm to its working position. Angle the head so that it can be lowered close to the ground. Keep the rotor clear of the material to be cut.

Start the rotor by engaging the lever **L** and increase the tractor PTO speed to 540 RPM.

Lower the head into position and move forward at a suitable speed for the type and quantity of material to be cut.

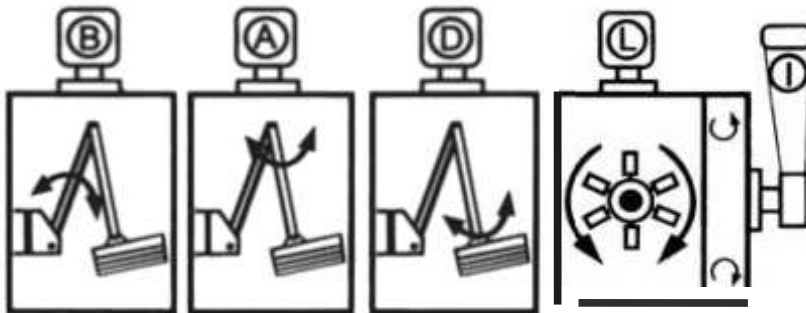

WARNING Even with the guards fitted some material may be ejected from the mower. All persons and animals need to be kept out of the working area.

Keeping the flail head horizontal to ground level allows the machine to be used with the greatest safety.

Always keep a clear safe working zone of at least 10 meters (33ft). Check frequently that no one has entered the working zone, stop immediately if this is the case.

When working on the roadside with traffic, always place warning signs to alert passing traffic. Be aware of passing traffic and be prepared to stop immediately.

When working in areas where there are stones, raise the machine so that it does not come into contact with the stones and increase the safe working zone to 20 meters+ (66ft+).

Cutting Hedges, Reeds & Shrubs

When the material to be cut exceeds 70-80 cm (28" - 32") in height, it will take more than one pass to complete the job, cutting 20-30 cm (8" - 12") maximum on each pass.

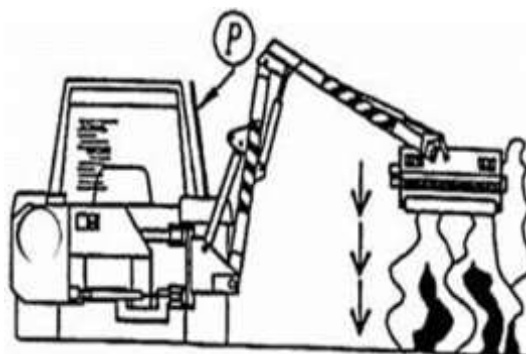

4. OPERATING ADVICE (continued)

The rotor of the machine can be operated In either direction using levers L & I.

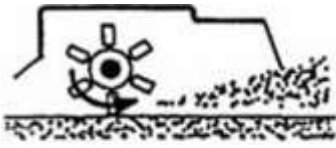

Rotor turning up at the front

Use for grass, ditch mowing & light hedge cutting

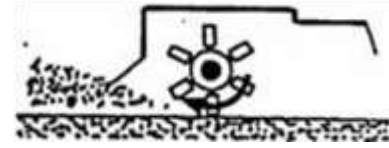

Rotor turning down at the front

Use for heavy growth

The cutting head must be lowered slowly until it is in work position. NEVER drop the running head. When you have to cut at ground level (grass etc.) the cutting head must be lowered slowly until the roller is just exerting a small pressure on the ground.

Always keep the rotor and roller clear of rocks, stones, stumps etc.

Keep the rotor free from wire, as this can be very dangerous if it wraps around the rotor. If you meet a large obstacles or you see wire twist around the rotor STOP IMMEDIATELY. Remove the obstacle or the wire before starting again.

The operator can avoid normal obstacles by slowing down and moving the position of the head.

Cutting Head

The rotor of cutting head is balanced before it is assembled into the head, this makes for vibration free operation. If the rotor should vibrate or loose one or more blades STOP IMMEDIATELY. When you stop the machine, clean the rotor and check that no flails or bolts are missing; if they are replace them immediately with only genuine spare parts.

Vibration can also be the consequence of a shock against a solid object. In this case the rotor must be rebalanced, repaired or even replaced.

Transit

Reduce the reach of the cutting arm by operation the lever. Turn the flail head until it is nearly perpendicular to the angling arm. Using the levers swing the cutter arm to the rear. Operate the reach lever until the arm is completely closed. The hedge cutter is ready for transport on the road.

PTO Shaft

Before starting, make sure all safety shields are in place & the safety guards cover the PTO shaft when extended. When attaching ensure the sprung locking collar slides freely and is securely in the groove on the PTO to avoid this coming loose. Always replace worn or damaged PTO shafts.

Most PTO driven implements are supplied with a standard sized PTO shaft. As all tractors vary this often means cutting it down to size. See section for PTO shaft resizing or consult an agricultural engineer if unsure.

5. CUTTING HEIGHT ADJUSTMENT

Safety: Ensure tractor and machine is stopped & keys out of ignition before set-up/maintenance.

Note: Clearance of blades to the ground should be at least 50mm and higher on un-even ground.

Safety: Always wear protective gloves and take care when working with sharp blades.

The cutting height should be adjusted for any ground level cutting. This should be set to suit the land and also the length of grass or density of weeds. The cutting height can be set for longer grass or overgrown areas by adjusting the roller on the machine.

Roller Adjustment

1. Loosen bolt **2** and remove bolt **1** on both sides of the machine.
2. Adjust roller by aligning the selected hole in the roller support bracket at position **1** (using the hole closest to the ground gives the highest working height).
3. Put bolt **1** into the selected hole and re-tighten bolts **1** and bolts **2**.

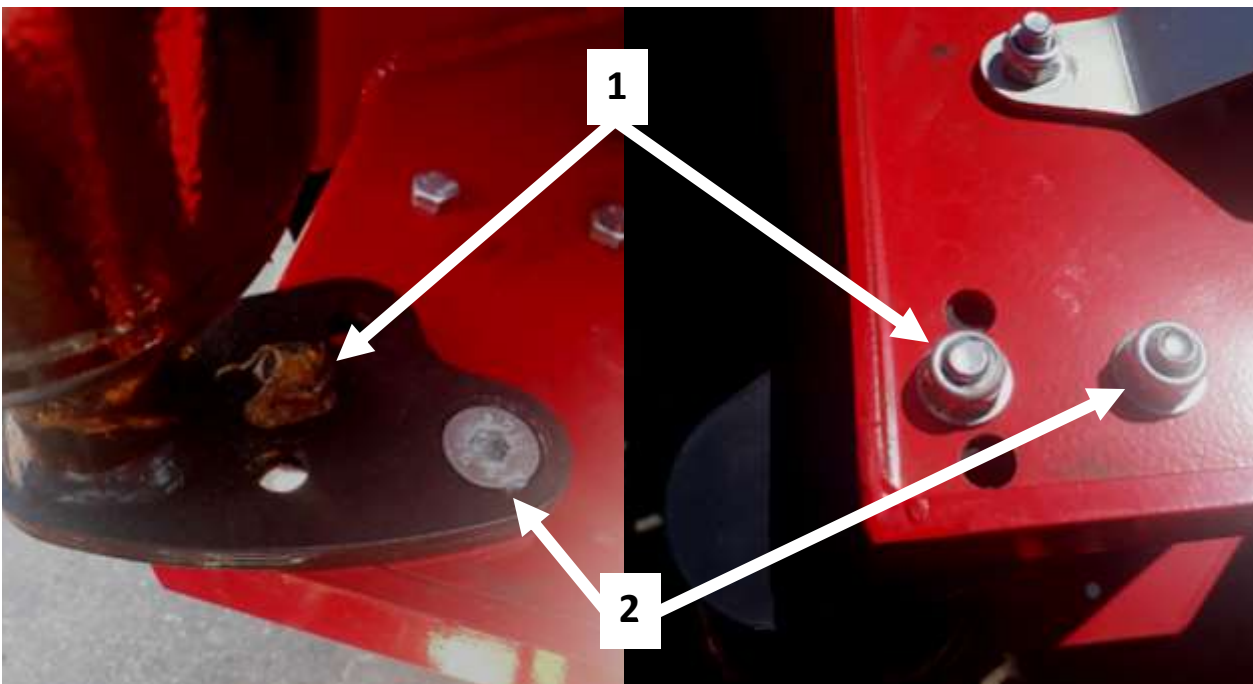

Material Type	Maximum cutting diameter
Hardwood	3cm (1.1")
Softwood	6cm (2.3")

6. SAFETY PRECAUTIONS

Always follow these guidelines to ensure maximum safety when operating the machine.

The driver must fully understand the controls and the capacity of the tractor. It is always recommended the driver practices the controls and the working of the hedge mower in a safe location BEFORE beginning work. Make sure that the P.T.O speed of the tractor is 540 RPM.

Working on Slopes

When working high with the reach fully in it is possible for the main arm balance to unbalance the tractor/machine. Always work at the slowest speed possible on slopes and avoid any circumstances which allow the machine and tractor to become off balance. Tractor wheel weights and front weights are necessary for all operations.

High Voltage Cables

It cannot be stressed enough the dangers involved when working near high voltage electricity cables. Before attempting to work in these areas ensure you have read and fully understood the safety section of this manual. Avoid operating near high voltage cables if possible.

It is advisable that you consult your Local Power Company to obtain information regarding a safe procedure for working if working near high voltage cables is un-avoidable.

Extra special attention should be applied to Overhead Power Lines. It cannot be stressed enough the dangers that surround this capability, it is therefore vital that the operator is fully aware of the maximum height and reach of the machine, and that they are fully conversant with all aspects regarding the safe minimum distances that apply when working with machines in close proximity to Power Lines. (Further information on this subject can be obtained from the Health & Safety Executive or your Local Power Company).

Overhead Obstructions

Always be aware of the height of the machine when working or folded and take care especially when manoeuvring near or under bridges, buildings, power cables or any other obstacles you may encounter when moving your machine.

Using Cutting Head Off The Ground

The use of the flail head off the ground or at an angle other than horizontal to the ground can cause danger to the driver from debris. Always take safety precautions to protect the operator. Guards must be fitted to the side of the tractor for safety.

Always keep the cutting head as close to the tractor as possible to maintain the greatest stability. Never direct the cutting head and the flails towards the operator when the machine is in motion .

NEVER CUT ON THE BLIND SIDE OF THE HEDGE. It is impossible to see potential hazards or dangers and the position of the flail head could allow debris to be propelled through the hedge towards the tractor and the operator.

THE MANUFACTURER DECLINES ALL RESPONSIBILITY FOR ANY ACCIDENT CAUSED BY NON-OBSERVANCE OF THE INSTRUCTION MANUAL.

6. SAFETY PRECAUTIONS (continued)

Always follow these guidelines to ensure maximum safety when operating the machine.

Road Use

Before using the hedge cutter on the roadside, the operator must consult the authorities that control the upkeep of the roads, as the rules can be different from one area to another. The rules concerning the upkeep of the roads must always be followed.

Always use traffic signs, or any other systems recommended by the maintenance services. Make sure that they are in a correct position in relation to the work being carried out. Respect the movement of the traffic. Give enough time for pedestrians and cyclists to get clear of the working area at all times. Also obey the laws on the lighting/signage to be used on the tractor during work on the highway.

Use clear suitably sized warning signs to alert others to the nature of the machine working within that area. Signs should be placed at both ends of the work site. (It is recommended that signs used are of a size and type specified by the Department of Transport and positioned in accordance with their and the Local Highways Authority guidelines).

Bystander Safety

Never transport passengers on the tractor or machine. Make sure 'onlookers/bystanders' are clear of the working area of the machine. Never allow any one in front of the cutting head or in the radius of the cutting material and debris.

Never start the cutting head with the flails facing the operator or any other people. Always work the machine with the cutting head towards the material to be cut. Never pass under the hedge cutter.

You must always maintain adequate SAFETY zones around the machine.

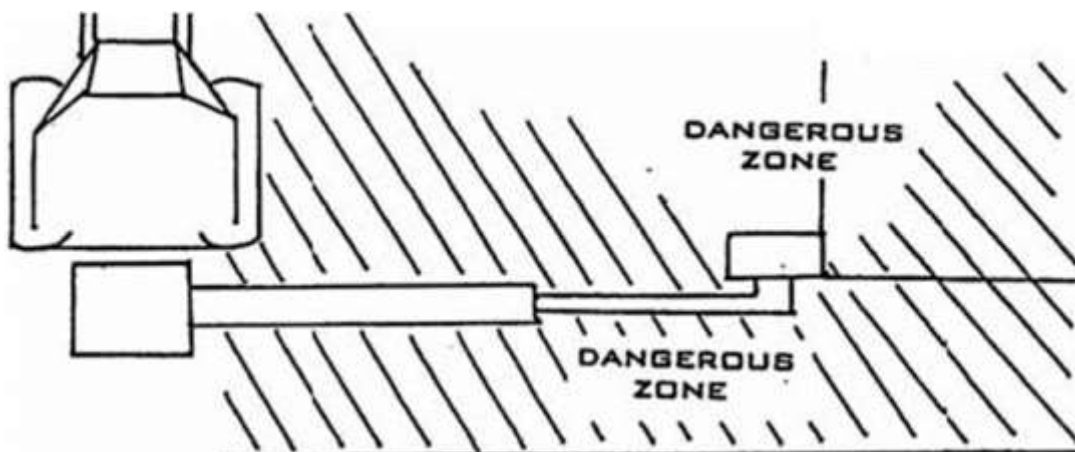

6. SAFETY PRECAUTIONS (continued)

Always follow these guidelines to ensure maximum safety when operating the machine.

This machine has the potential to be extremely dangerous. It is therefore imperative that the owner, and operator, read the full manual to ensure they are both fully aware of the dangers that do, or may exist, and their responsibilities surrounding its use. The operator of this machine is responsible not only for their own safety but equally for the safety of others who may come into the close proximity of the machine, as the owner you are responsible for both.

Potential Significant Dangers When In Use

- Being hit by debris thrown by rotating components.
- Being hit by machine parts ejected through damage during use.
- Being caught on a rotating power take-off (PTO) shaft.
- Being caught in other moving parts i.e.: belts, pulleys and cutting heads.
- Electrocution from Overhead Power Lines (by contact with or 'flashover' from).
- Being hit by cutting heads or machine arms as they move.
- Becoming trapped between tractor and machine when hitching or unhitching.
- Tractor overbalancing when machine arm is extended.
- Injection of high pressure oil from hydraulic hoses or couplings.
- Machine overbalancing when freestanding (out of use).
- Road traffic accidents due to collision or debris on the road.

Ensure the operator is protected from noise. Ear defenders should be worn and tractor cab doors and windows must be kept closed. Machine controls should be routed through proprietary openings in the cab to enable all windows to be shut fully.

Always work at a safe speed taking account of the conditions i.e.: terrain, highway proximity and obstacles around and above the machine.

Always disengage the machine, kill the tractor engine, remove and pocket the key before dismounting for any reason.

Always clear up all debris left at the work area, it may cause hazard to others.

Always ensure when you remove your machine from the tractor that it is left in a safe and stable position using the stands and props provided and secured if necessary.

6. SAFETY PRECAUTIONS (continued)

Always follow these guidelines to ensure maximum safety when operating the machine.

When Not To Use The Machine

Never attempt to use this machine if you have not been trained to do so. Never use a machine until you have read and understood the operator handbook, are familiar with, and practiced the controls.

- Never use the machine if the tractor does not have a cab or similar guards for operator protection.
- Never use a machine that is poorly maintained.
- Never use a machine if guards are missing or damaged.
- Never use a machine on which the hydraulic system shows signs of wear or damage.
- Never fit, or use, a machine on a tractor that does not meet the manufacturer's minimum specification level.
- Never use a machine fitted to a tractor that does not have suitable front, rear and side(s) cab guarding made of metal mesh or polycarbonate.
- Never use the machine if the tractor cab guarding is damaged, deteriorating or badly fitted.
- Never turn a machine cutting head to an angle that causes debris to be ejected towards the cab.
- Never start or continue to work a machine if people are nearby or approaching - Stop and wait until they are at a safe distance before continuing.
- **WARNING:** Flail blades may continue to 'freewheel' for up to 40 seconds after being stopped.
- Never attempt to use a machine on materials in excess of its capability.
- Never use a machine to perform a task it has not been designed to do.
- Never operate the tractor or machine controls from any position other than from the driving seat, especially whilst hitching or unhitching the machine.
- Never carry out maintenance of a machine or a tractor whilst the engine is running – the engine should be switched off, the key removed and pocketed.
- Never leave a machine unattended in a raised position – it should be lowered to the ground in a safe position on a level firm site.
- Never leave a tractor with the key in or the engine running.
- Never carry out maintenance on any part or component of a machine that is raised unless that part or component has been properly substantially braced or supported.
- Never attempt to detect a hydraulic leak with your hand – use a piece of cardboard.
- Never allow children near to, or play on, a tractor or machine under any circumstances.

7. HYDRAULIC OIL CHECK & MAINTENANCE

Safety: Ensure tractor and machine is stopped & keys out of ignition before set-up/maintenance.

Safety: Always follow manufacturers instructions for oils and lubricants.

Important Information

Hydraulic Oil Grade	Type 32 hydraulic oil (or equivalent)
Hydraulic Oil Tank Capacity	Approx. 55 litres
First Hydraulic Oil Change	200 hours use
Hydraulic Oil Change Frequency	250 hours

Hydraulic Oil Level Check

Check oil level when the unit is cold & the machine is level. Ensure different types of oils are not mixed in the machine, this also applies to old and new oil.

The hydraulic oil should be visible in the level indicator (/thermometer) on the side of the oil tank **A**. This also shows the current temperature. If the oil level is below the level indicator then the hydraulic oil in the oil tank should be topped up.

1. Unscrew and remove filler plug **B**.
2. Pour in the oil (a funnel or pipe is helpful here as it is a narrow filler).
3. Fill until the oil can be seen in the level indicator **A**.
4. Replace the filler plug **B**.

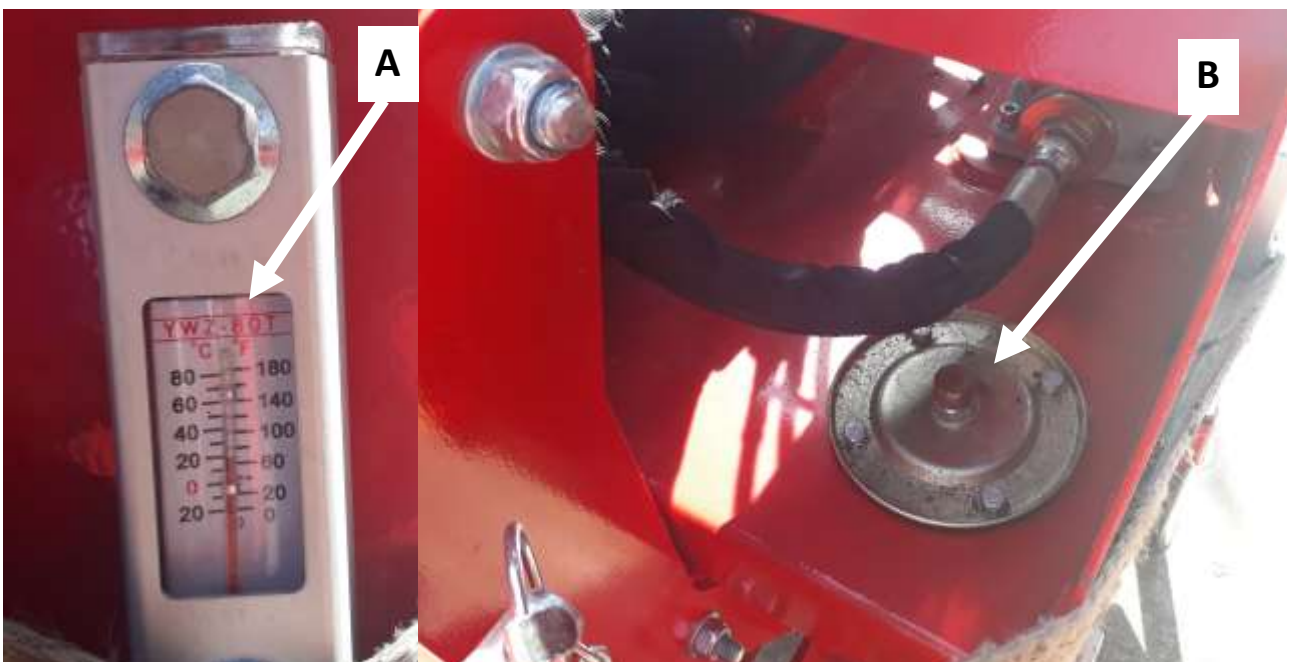

7. HYDRAULIC OIL CHECK & MAINTENANCE (continued)

Safety: Ensure tractor and machine is stopped & keys out of ignition before set-up/maintenance.

Safety: Always follow manufacturers instructions for oils and lubricants.

Changing Hydraulic Oil

Ensure that the machine has not been running before changing the oil. If it has then wait until the unit is completely cooled down before changing oil.

1. Remove the filler plug on the top of the oil tank **C**.
2. Then either use an oil pump to remove the oil or, if not available, unbolt the lower pipe from the oil tank **D**.
3. Drain the oil.
4. Then replace fixing/pipe **D** ensuring this is secure.
5. Fill with hydraulic oil through filler **C** until the oil is visible through the level indicator **A**.
6. Replace filler **C**.

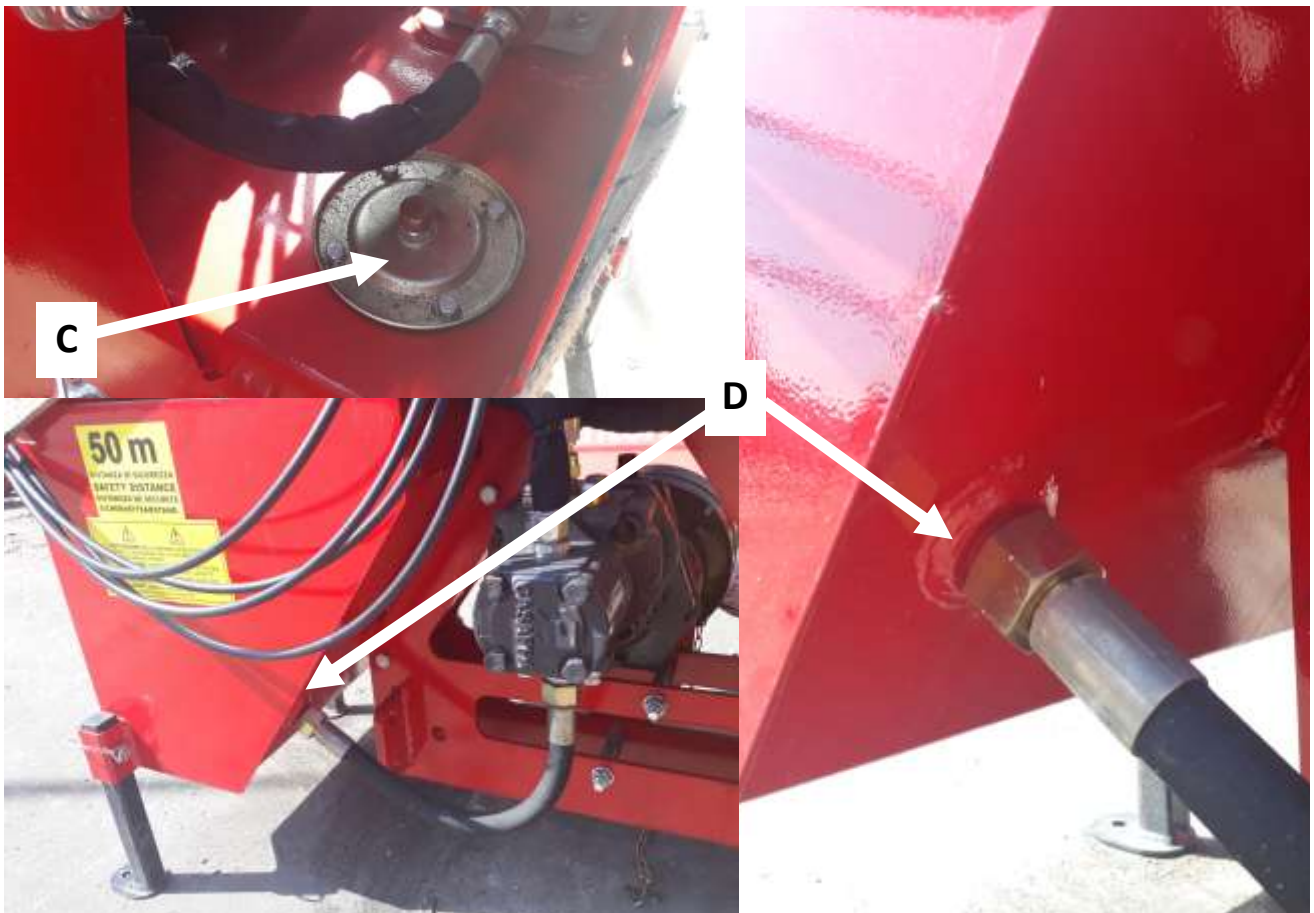

Oil Change #1	Oil Change #2	Oil Change #3	Oil Change #4	Oil Change #5	Oil Change #6
/ /	/ /	/ /	/ /	/ /	/ /

8. GEARBOX MAINTENANCE

Safety: Ensure tractor and machine is stopped & keys out of ignition before set-up/maintenance.

Safety: Always follow manufacturers instructions for oils and lubricants.

Important Information

Gear Oil Grade	80W90 gear oil for all conditions (or equivalent)
Gearbox Oil Level	Approx. 200 ml
First Gear Oil Change	50 hours use
Gear Oil Change Frequency	250 hours/yearly (whichever is first)

Gear Oil Level Check

Check oil level when the unit is cold & the machine is level. Oil level should be checked periodically to ensure the machine is working optimally. Ensure different types of oils are not mixed in the machine, this also applies to old and new oil.

1. Unscrew and remove filler plug **A**.
2. Use a dipstick or similar to check oil level, this should be approx. half full.
3. Top up the oil through filler **A** if needed to the required level.
4. Replace filler plug **A**.

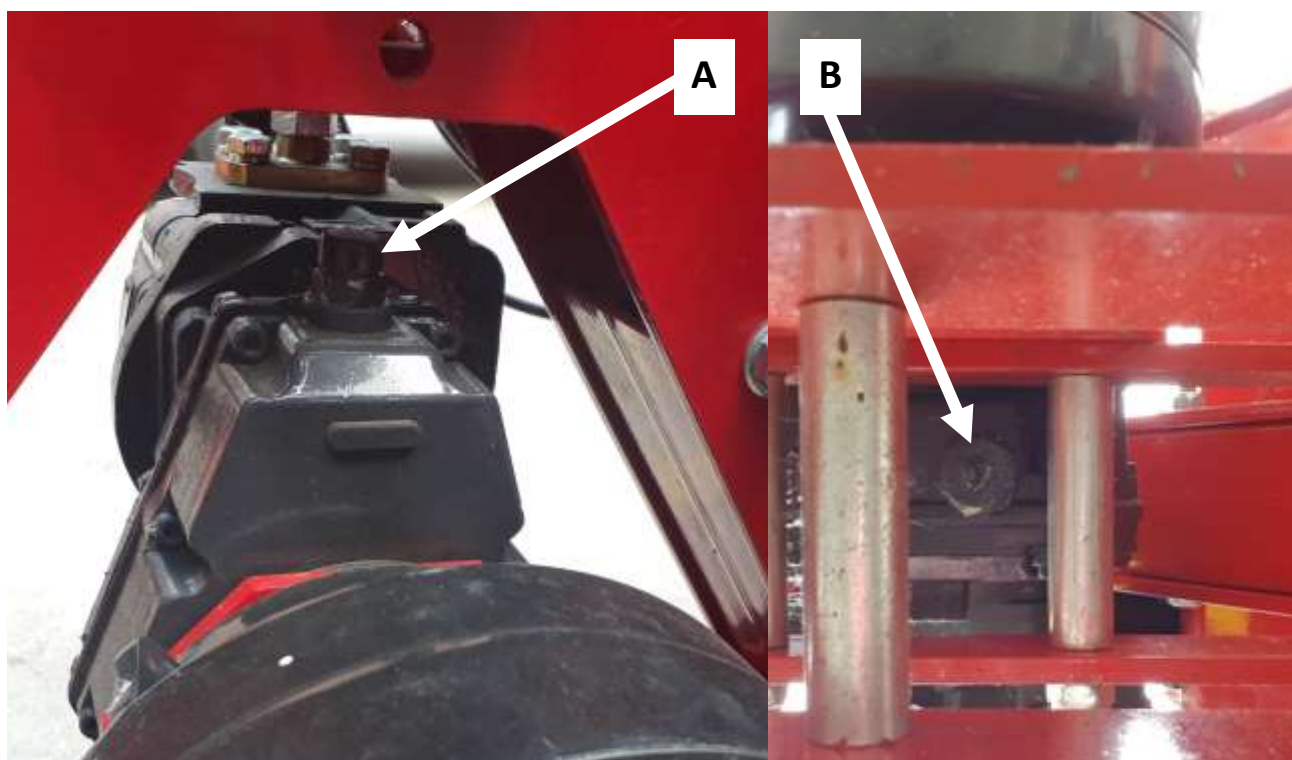

8. GEARBOX MAINTENANCE (continued)

Safety: Ensure tractor and machine is stopped & keys out of ignition before set-up/maintenance.

Safety: Always follow manufacturers instructions for oils and lubricants.

Changing Gear Oil

When changing oil ensure that the unit and oil is cold. Gear oil should be changed as per the schedule to ensure the machine is working optimally. Ensure different types of oils or old and new oil is not mixed when carrying our maintenance.

1. Unscrew and remove filler plug **A**.
2. Place a tray under the gear box to catch the old oil.
3. Unscrew and remove drain plug **B** (underneath the gear box).
4. This will drain the oil from the gearbox.
5. Replace drain plug **B**.
6. Fill the oil through filler **A** (approx. 200ml).
7. Check oil level using a dipstick or similar, this should be approx. half full.
8. Replace filler plug **A**.

Always make sure to dispose of old oils in the correct manner. Check the oil manufacturers instructions for correct disposal methods.

Oil Change #1	Oil Change #2	Oil Change #3	Oil Change #4	Oil Change #5	Oil Change #6
/ /	/ /	/ /	/ /	/ /	/ /

9. SERVICING & MAINTENANCE

Safety: Store all lubricants away from excessive heat, dust, moisture and contaminants.

Safety: Ensure tractor and machine is stopped & keys out of ignition before set-up/maintenance.

Important Information

Grease Type	Multi-purpose lithium based grease
Grease Frequency	Check every 4-8 hours (top up if required)

Greasing & Lubrication Points

1. Bearings on the blade rotor x2
2. Bearings on the roller x2
3. Hydraulic RAMs on the arm x6
4. All arm pivot points
5. PTO shaft x2

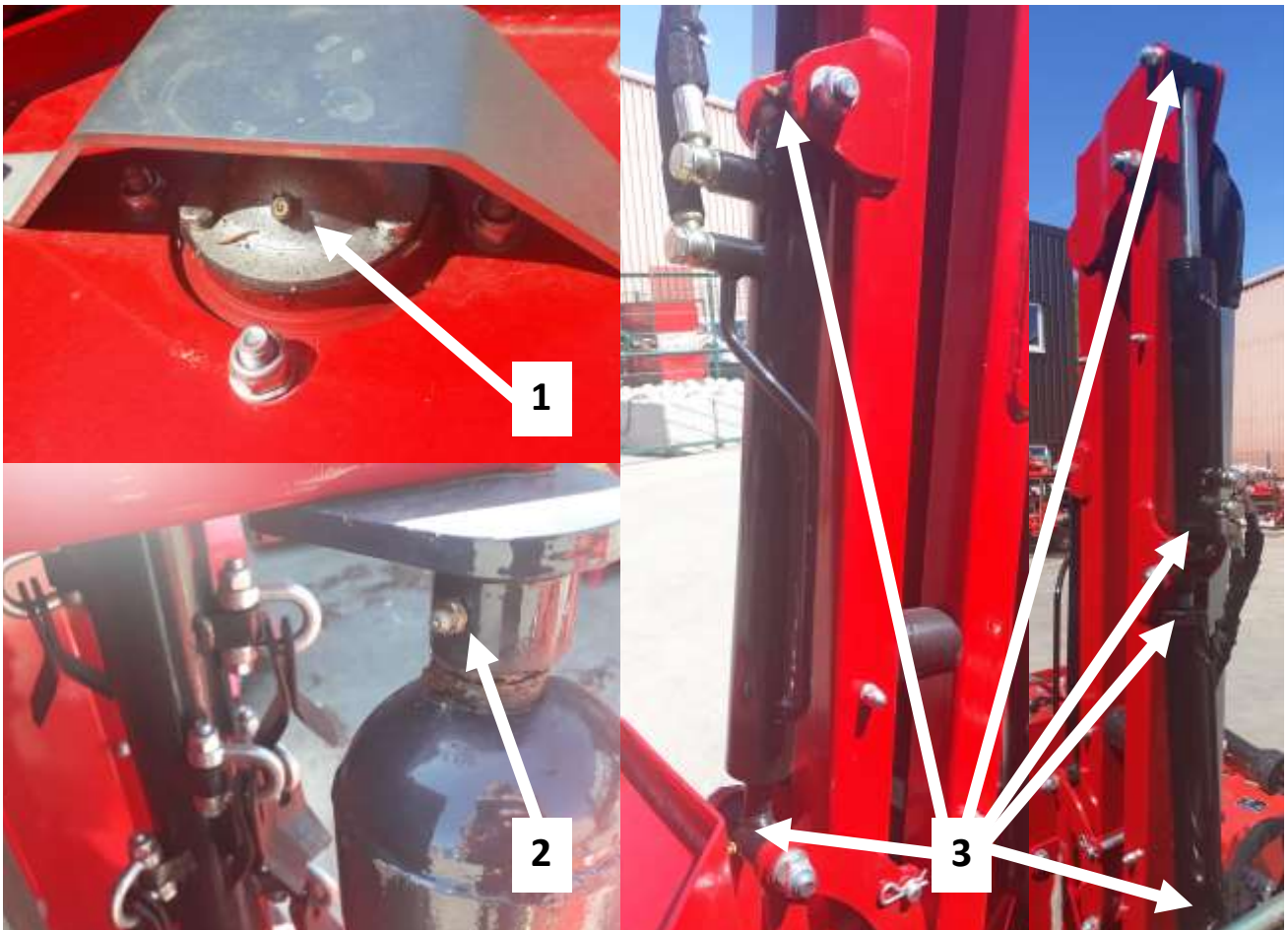

Wipe grease nipples with a clean cloth before greasing to avoid injecting any dirt and grit. Press grease into each grease nipple three to five times. We recommend using a hand-held grease gun for best results.

If grease nipples will not take grease, remove and clean thoroughly. Also clean lubricant passageway. If you notice any grease points are broken replace or repair them immediately.

9. SERVICING & MAINTENANCE (continued)

Safety: Store all lubricants away from excessive heat, dust, moisture and contaminants.

Safety: Ensure tractor and machine is stopped & keys out of ignition before set-up/maintenance.

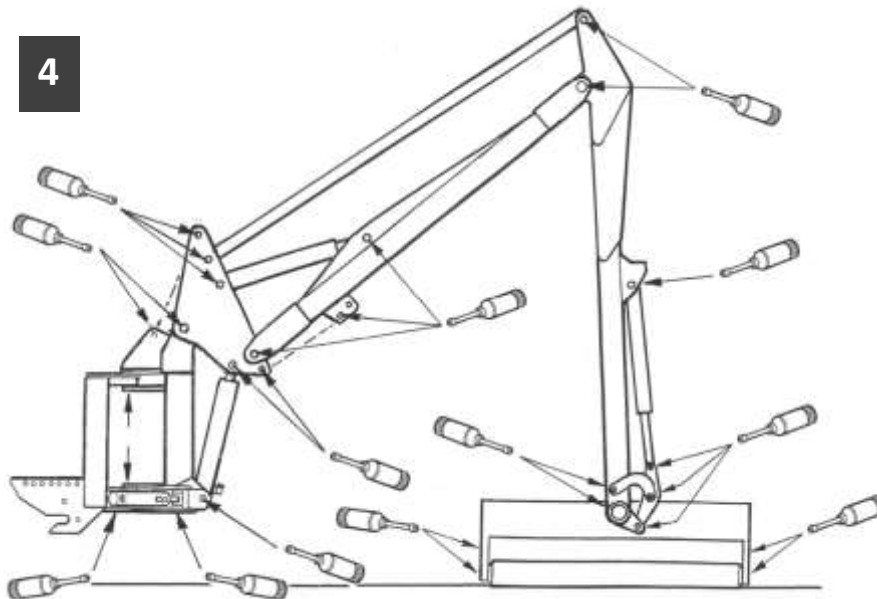

Filters

Check the filters located on the entry and exit of the fuel tank. Replace these if needed.

Filter Check	Check filters every 50 hours/yearly
First Filter Change	Replace after first 50 hours use (or as needed)
Filter Change Frequency	Replace every 250 hours (or as needed)

Other Maintenance

Blades: Check condition of the blades and replace if worn/broken. Always take care when handling blades, wear gloves and use suitable tools for changing blades. If blades are replaced check they are balanced in order to avoid any excessive vibration.

Oils: Ensure oil levels are checked and topped up when needed. Replace any oils and filters per the schedule.

PTO Shaft: Check the condition of your PTO shaft and replace if worn or damaged immediately.

Cleaning: Ensure the cutter is cleaned of grass. Remove debris from any moving parts to prevent entanglement. Do not spray water on bearings when cleaning with a high pressure washer.

Bearings: Check the bearings on the blade rotor and roller. If seals are damaged replace bearings. Run the mower without a load for 3-5 minutes to check bearings are operating smoothly.

Paintwork: Re-coat any damaged paintwork to prevent corrosion.

Storage: Store the machine in a dry, level area. Support the frame if necessary.

The periods recommended are based on normal operating conditions. Severe or unusual conditions may require more frequent maintenance.

10. PARTS DIAGRAM 1 BODY

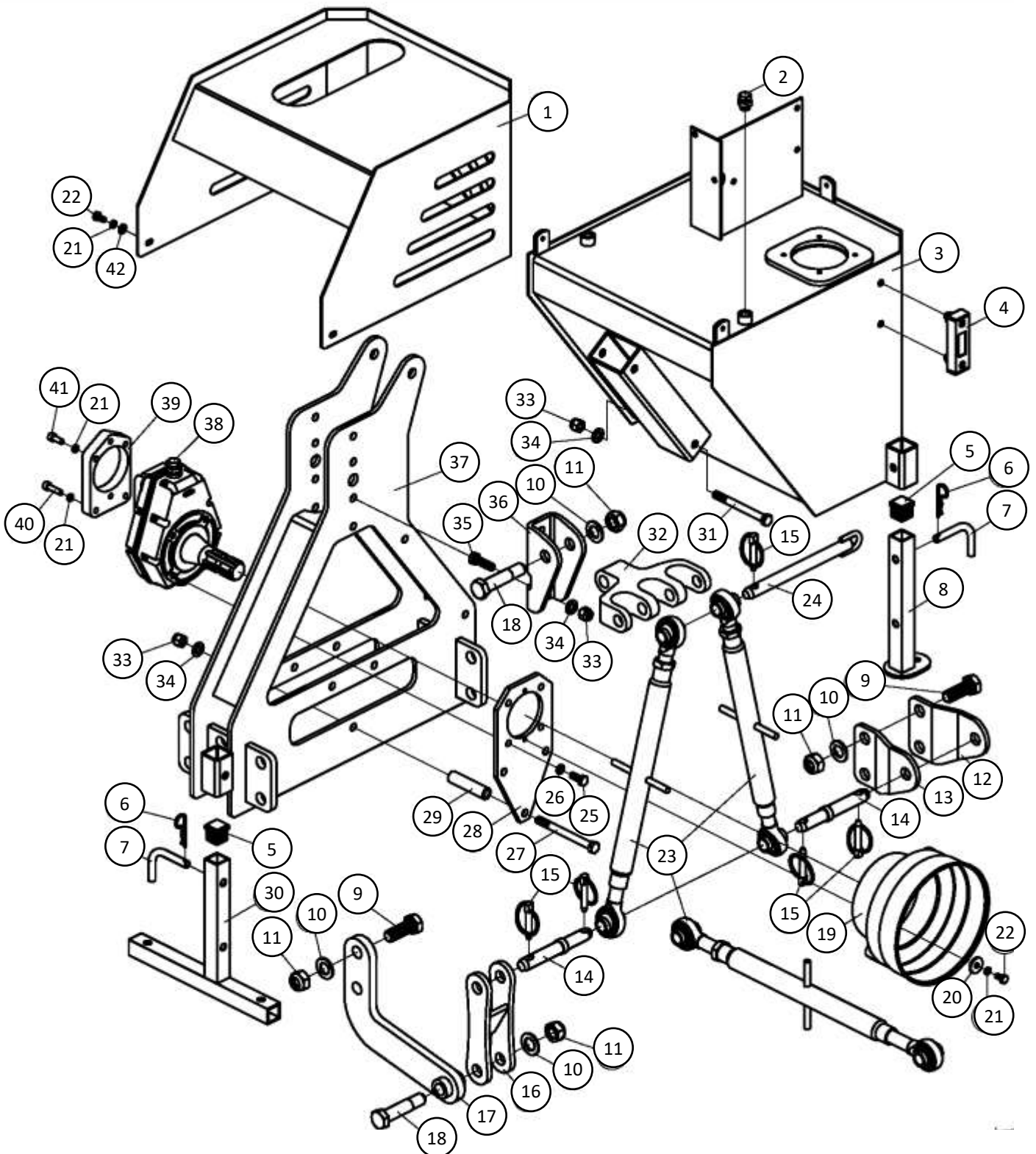

Dia No.	Number	Part Number	Part Description	Qty
1	802770115	AM60.03.016	Oil tank cover	1
2	703070084	CBW-00-011	Air plug M16X1.5	2
3	802770118	AM60.03.017Y-1	Hydraulic Tank	1
4	509010012	JB7941.2-B80	Hydraulic Level Window	1
5	700920105	EF100.00.117	Plastic End Cap	3
6	703190209	1G-150-01-142	R Clip	4

12. PARTS DIAGRAM 1 BODY (continued)

Dia No.	Number	Part Number	Part Description	Qty
7	800920101	EF100.00.111A	L-Shape Pin	3
8	802770128	AM60.03.018	Supporting Leg/Stand	2
9	501011198	GB5783-M20X55	Bolt M20X55	4
10	506010061	GB97.1-20	Plain washer	9
11	503010767	DIN985-M20	Locking Nut	9
12	702770078	AM60.03.114	Lower Link Plate (Right)	1
13	702770079	AM60.03.115	Lower Link Plate (Left)	1
14	702770077	AM60.03.113	Lower Link Pin	2
15	700080010	200.56.011	Lynch Pin	5
16	802770135	AM60.03.021	Floating Lower Link Bracket	1
17	802770138	AM60.03.022	Floating Lower Link Bracket weldment	1
18	501014279	GB27-M20X95	Articulation bolt	2
19	703400008	FM120.00.199	PTO shaft cover	1
20	506010035	GB96.1-8	Large plain washer	10
21	506030035	GB93-8	Spring washer	5
22	501011098	GB5783-M8X16	Bolt M8X16	5
23	802770134	AM60.03.020	Adjustable Link Arm	3
24	802770131	AM60.03.019	Link Arm Pin (3 Link Arms)	1
25	501011843	GB5786-M10X1.25X25	Fine thread screw bolt	4
26	506030036	GB93-10	Spring washer	4
27	501014700	GB5782-M12X130	Bolt M12X130	3
28	702770066	AM60.03.102	Gear Box Fixing Plate	1
29	702770065	AM60.03.101	Spacer bush	3
30	802770080	AM60.03.010	Support Leg (Right)	1
31	501010765	GB5782-M12X120	Bolt M12X130	2
32	702770076	AM60.03.112	Link Arm Bracket	1
33	503010763	DIN985-M12	Locking Nut	3
34	506010057	GB97.1-12	Plain washer	8
35	501011128	GB5783-M12X40	Bolt M12X40	3
36	702770075	AM60.03.111	Top Link Bracket	1
37	802770083	AM60.03.011	Bed frame Body	1
38	802770211	AM60.03.012	Oil pump transmission box	1
39	702770146	AM60.04.102	Gear box Connecting Plate	1
40	505011417	GB70.1-M8X30	Bolt M8X30	2
41	505011415	GB70.1-M8X20	Bolt M8X20	2
42	506010054	GB97.1-6	Plain washer	4

11. PARTS DIAGRAM 2 HYDRAULICS

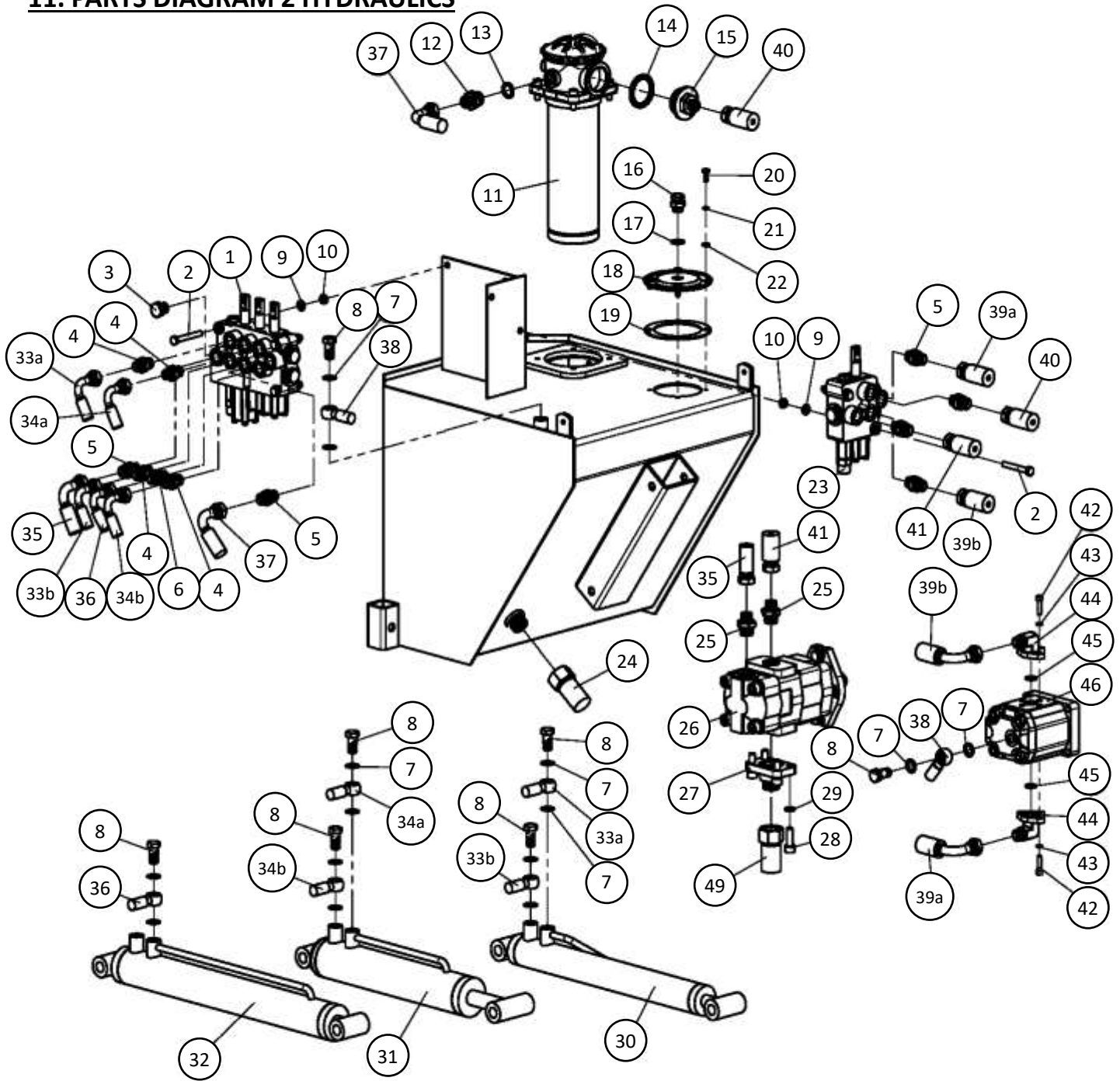

Dia No.	Number	Part Number	Part Description	Qty
1	702770159	AM60.04.022Y	Three Way Valve Block	1
2	501010741	GB5782-M8X60	Bolt M8X60	5
3	516010003	ZBT32001.3-ZG3/8-19"	Inner Tapered Plug	1
4	702930544	MBH-8.08.302Y	Oil In/Out Connector	3
5	700250036	1CB-18-06WD	Connector M18X1.5-G3/8	6
6	702930546	MBH-8.08.305Y	Valve Connector	2
7	510015239	JB982-14	Bonded Washer	14
8	501014707	GB3541-M14X1.5	Banjo Bolt	6
9	506010055	GB97.1-8	Plain washer	5
10	503010761	DIN985-M8	Locking Nut	5

11. PARTS DIAGRAM 2 HYDRAULICS (continued)

Dia No.	Number	Part Number	Part Description	Qty
11	702770173	RFA-100X30L	Return Oil Filter	1
12	706530042	1CM-18WD	M18X1.5 Adapter	1
13	510013132	GB3452.1-G-18X2.65	O Ring (Seal)	1
14	510015250	JB982-42	Bonded Washer	1
15	702770147	AM60.04.104-1	Oil Filter Adapter	1
16	703070084	CBW-00-011	Air plug M16X1.5	1
17	510015240	JB982-16	Bonded Washer	1
18	702930505	MBH-8.08.117	Hydraulic Tank Cap	1
19	702930506	MBH-8.08.118	Hydraulic Tank Gasket Cap	1
20	501011087	GB5783-M6X12	Bolt M6X12	4
21	506030034	GB93-6	Spring washer	4
22	506010054	GB97.1-6	Plain washer	4
23	702770154	AM60.04.017Y	Single valve	1
24	702770148	AM60.04.011-1	Oil pump inlet tube	1
25	705190067	1CB-18-08WD	Hydraulic Connector M18X1.5-G1/2X14	2
26	702770172	CBHY-G25/F4.5-ATP	Gear Pump	1
27	702770145	AM60.04.101-1	Oil pump Inlet Adapter	1
28	505011430	GB70.1-M10X30	Bolt M10X30	4
29	506030036	GB93-10	Spring washer	4
30	702770153	AM60.04.016-1	Swing arm cylinder	1
31	702770160	AM60.04.023	Small arm cylinder	1
32	702770152	AM60.04.015	Big arm cylinder	1
33	702770157	AM60.04.020	Swing arm cylinder tube	2
34	702770155	AM60.04.018	Small arm cylinder tube	2
35	702770198	AM60.04.025Y	Oil pump Triple Valve Tube	1
36	702770156	AM60.04.019	Big arm cylinder tube	1
37	702770158	AM60.04.021Y	Triple valve outlet tube	1
38	702770150	AM60.04.013	Oil Return Tube	1
39	702770151	AM60.04.014	Oil Filling Tube	2
40	702770197	AM60.04.024Y	Single Valve for Oil Tube Filter	1
41	702770149	AM60.04.012Y	Oil pump outlet tube	1
42	505011416	GB70.1-M8X25	Bolt M8X25	6
43	506030035	GB93-8	Spring washer	6
44	702780010	AM60.02.104-2	Oil In/out Connector	2
45	510013139	GB3452.1-G-23.6X2.65	O Ring (Seal)	2
46	702770169		Hydraulic motor	1

12. PARTS DIAGRAM 3 CONTROLS

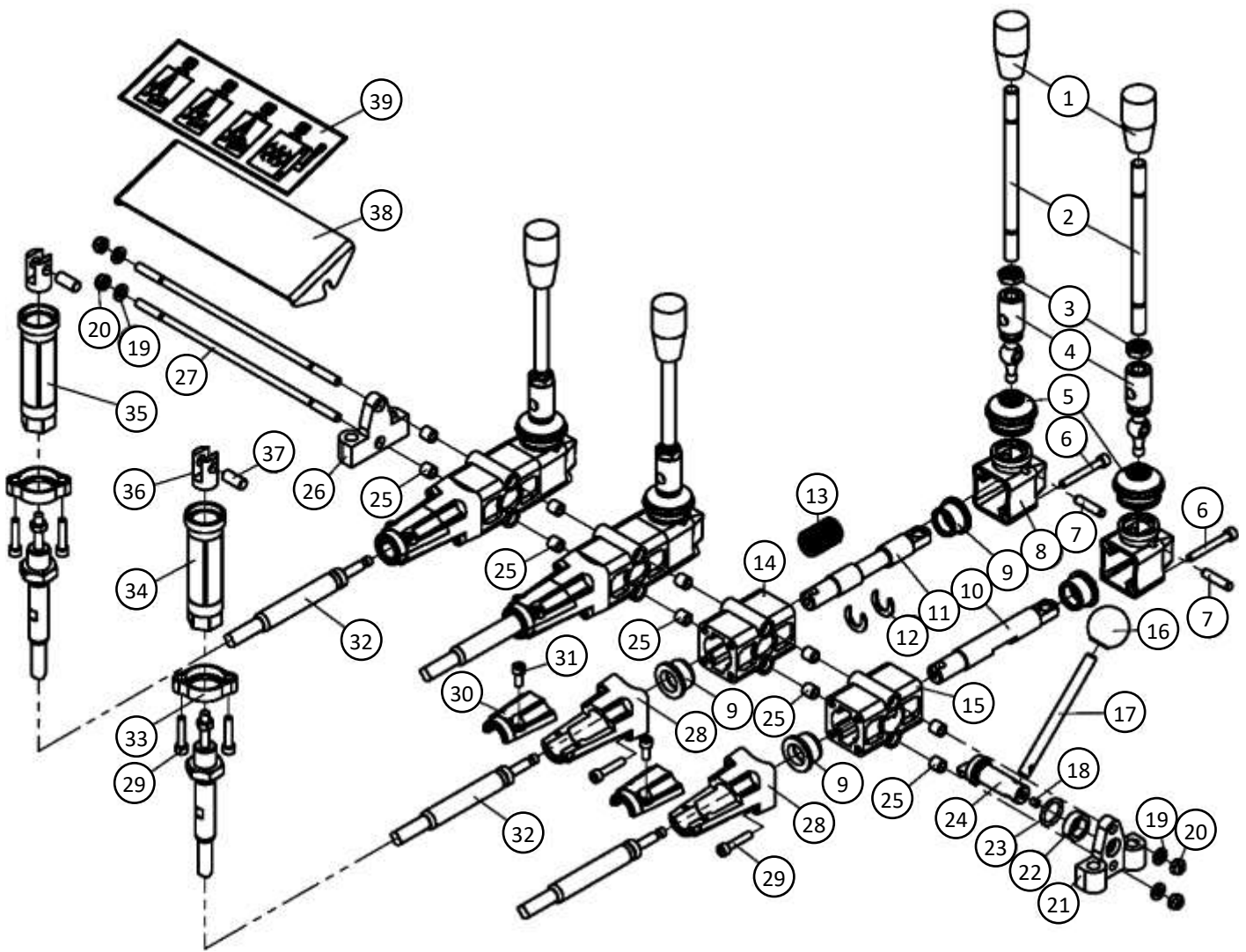

Dia No.	Number	Part Number	Part Description	Qty
1	702830121	BH-6.07.091	Plastic Handle	4
2	702910335	MBH-6.08.108	Joystick (short)	4
3	503010099	GB6172.1-M10	Nut	4
4	702770020	AM60.01.120	Joystick Mounting Block	4
5	702770019	AM60.01.119	Protecting Boot	4
6	505011396	GB70.1-M5X40	Bolt M5X40	8
7	508010099	GB119.1-B-6X26	Roll Pin	4
8	702770015	AM60.01.114	Upper cover	4
9	702770010	AM60.01.109	Flange bush	8
10	702770216	AM60.01.118A	Control Pull Rod 1	1

12. PARTS DIAGRAM 3 CONTROLS (continued)

Dia No.	Number	Part Number	Part Description	Qty
11	702770213	AM60.01.111A	Control Pull Rod 2	3
12	702770022	AM60.01.122	Half Moon Clip	6
13	702770011	AM60.01.110	Release spring	3
14	702770014	AM60.01.113	Outer Casing	3
15	702770017	AM60.01.117	Outer Casing (Locking)	1
16	702770171	AM60.04.092	Round Handle	1
17	702770008	AM60.01.107	Blade Lock Joystick	1
18	505020541	GB78-M5X8	Bolt M5X8	1
19	506010054	GB97.1-6	Plain washer	4
20	503010759	DIN985-M6	Locking Nut	4
21	702770006	AM60.01.105	Mounting Bracket	1
22	702770005	AM60.01.104	Bush	1
23	510013130	GB3452.1-G-16X2.65	O Ring (Seal)	1
24	702770007	AM60.01.106	Lock Shaft	1
25	702770004	AM60.01.103	Locating Sleeve/Bush	10
26	702770003	AM60.01.102	Mounting Bracket	1
27	702770002	AM60.01.101	Screw Rod Mechanism	2
28	702770214	AM60.01.112A	Lower Cover	4
29	505011393	GB70.1-M5X25	Bolt M5X25	16
30	702770215	AM60.01.123A	Small Lower cover	4
31	505011389	GB70.1-M5X12	Bolt M5X12	8
32	802770212	AM60.01.011A	Cable Fitting	4
33	702770191	AM60.01.201	Connecting Plate	4
34	702770192	AM60.01.202	Pressure Casing	3
35	702770193	AM60.01.203	Flared Pressure Casing	1
36	702770194	AM60.01.204	Swivel Aluminum Mounting	4
37	702770195	AM60.01.205	Pin	4
38	702770224	AM60.01.115	Label Mounting Plate	1
39			Label	1

13. PARTS DIAGRAM 4 ARM

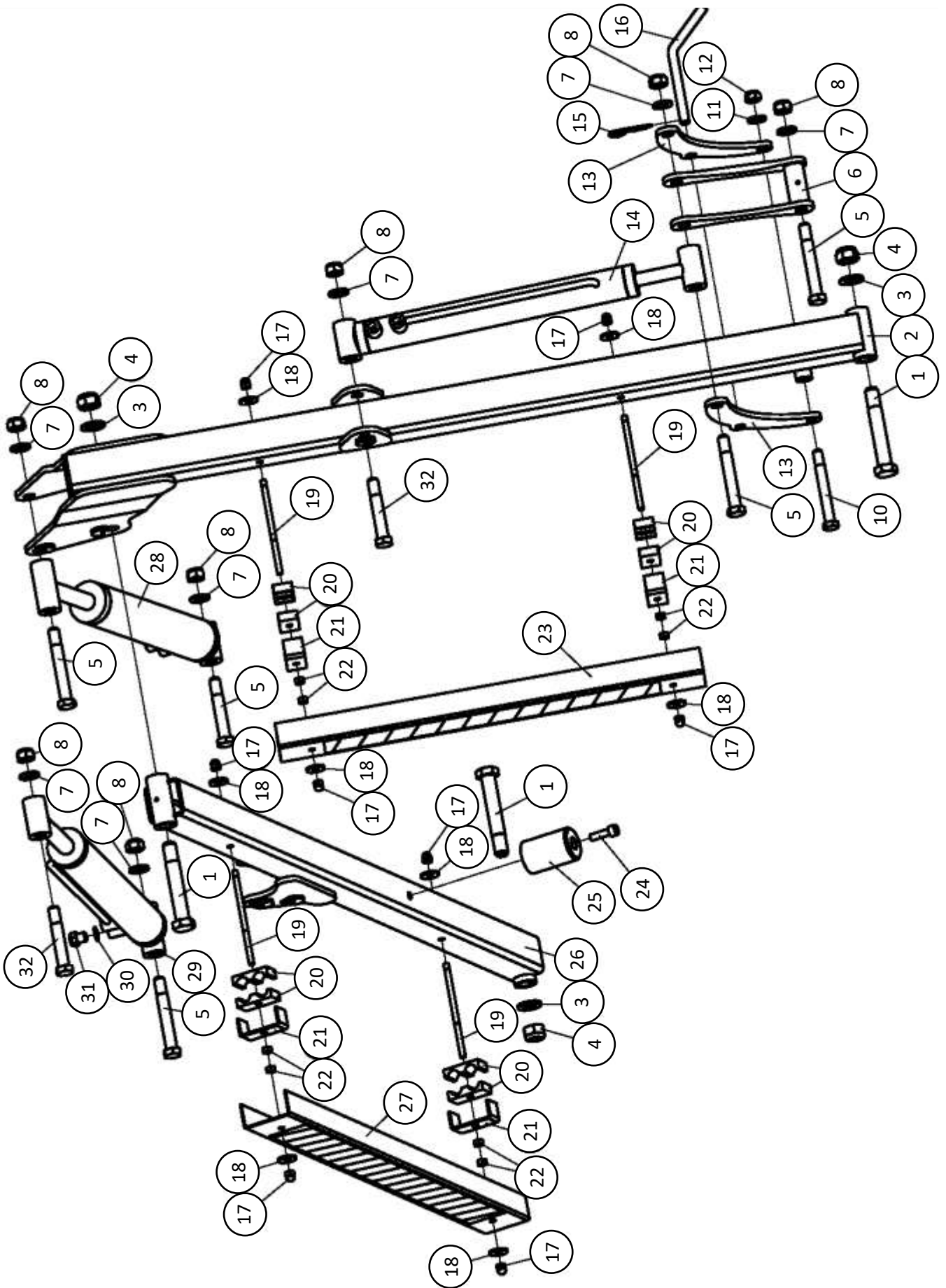

13. PARTS DIAGRAM 4 ARM (continued)

Dia No.	Number	Part Number	Part Description	Qty
1	501014283	GB27-M20X130	Articulation bolt	3
2	802770096	AM60.03.014	Small support arm	1
3	506010061	GB97.1-20	Plain washer	9
4	503010767	DIN985-M20	Locking Nut	9
5	501014240	GB27-M16X120	Articulation bolt	4
6	802770093	AM60.03.013	Hinged Plate	1
7	506010059	GB97.1-16	Plain washer	7
8	503010765	DIN985-M16	Locking Nut	7
10	501014220	GB27-M14X120	Articulation bolt	1
11	506010058	GB97.1-14	Plain washer	1
12	503010764	DIN985-M14	Locking Nut	1
13	702770067	AM60.03.103	Swing arm plate	2
14	702770153	AM60.04.016-1	Swing arm cylinder	1
15	703190209	1G-150-01-142	R Clip	4
16	702770074	AM60.03.110	Locking Pin	1
17	503020124	GB923-M8	Nut with Cap	8
18	506010035	GB96.1-8	Extra large plain washer	10
19	702770073	AM60.03.109	Threaded Bar	4
20	702770069	AM60-03-105	Oil Hose Clip	8
21	702770070	AM60.03.106	Oil Hose Plate	4
22	503010045	GB6170-M8	Nut	8
23	702770071	AM60.03.107	Oil Hose Guard	1
24	505011431	GB70.1-M10X35	Bolt M10XX35	1
25	702770068	AM60.03.104	Bump Stop/ Rubber Mount	1
26	802770108	AM60.03.015	Big support arm	1
27	702770072	AM60.03.108	Oil tube long cover	1
28	702770160	AM60.04.023	Small Arm Cylinder	1
29	702770152	AM60.04.015	Big arm cylinder	1
30	510015239	JB982-14	Bonded Washer	1
31	702770174	AM60.04.090	Breather Plug	1
32	501014238	GB27-M16X100	Articulation bolt	3

14. PARTS DIAGRAM 5 CUTTING HEAD

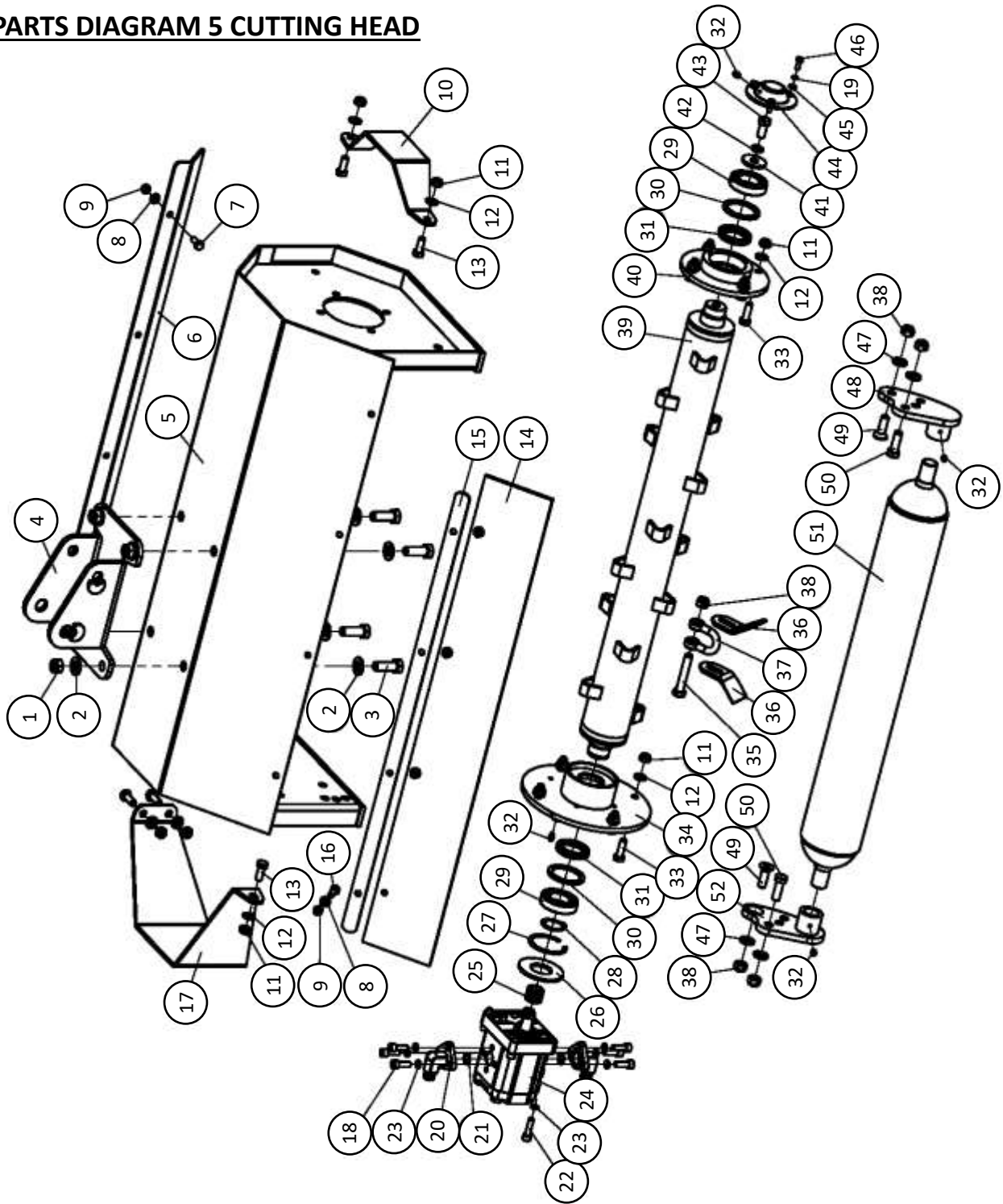

Dia No.	Number	Part Number	Part Description	Qty
1	503010764	DIN985-M14	Locking Nut	4
2	506010058	GB97.1-14	Plain washer	8
3	501011142	GB5783-M14X40	Bolt M14X40	4
4	802770061	AM60.02.017	Hitch Frame Plate	1
5-1	802770037	AM60.02.010	Cutting Head Body (60)	1
5-2	802780005	AM80.02.010	Cutting Head Body (80)	1
5-3	806830004	AM100.02.010	Cutting Head Body (100)	1

14. PARTS DIAGRAM 5 CUTTING HEAD (continued)

Dia No.	Number	Part Number	Part Description	Qty
6-1	702770033	AM60.02.110	Cutting Head Plate (60)	1
6-2	702780002	AM80.02.110	Cutting Head Plate (80)	1
6-3	706830001	AM100.02.110	Cutting Head Plate (100)	1
7	501011099	GB5783-M8X20	Bolt M8X20	4
8	506010055	GB97.1-8	Plain washer	8
9	503010760	DIN985-M8	Locking Nut	8
10	702770031	AM60.02.108	Rotor End Plate Guard	1
11	503010762	DIN985-M10	Locking Nut	13
12	506010056	GB97.1-10	Plain washer	13
13	501011112	GB5783-M10X25	Bolt M10X25	5
14-1	702770035	AM60.02.112	Rubber Guard (60)	1
14-2	702780004	AM80.02.112	Rubber Guard (80)	1
14-3	706830003	AM100.02.112	Rubber Guard (100)	1
15-1	702770034	AM60.02.111	Rubber Guard Plate (60)	1
15-2	702780003	AM80.02.111	Rubber Guard Plate (80)	1
15-3	706830002	AM100.02.111	Rubber Guard Plate (100)	1
16	501011100	GB5783-M8X25	Bolt M8X25	4
17	702770026	AM60.02.103	Motor End Plate Guard	1
18	505011416	GB70.1-M8X25	Bolt M8X25	6
19	506030034	GB93-6	Spring washer	3
20	702780010	AM60.02.104-2	Motor Oil In/Out Connector	2
21	510013139	GB3452.1-G-23.6X2.65	O Ring (Seal)	2
22	505011417	GB70.1-M8X30	Bolt M8X30	4
23	506030035	GB93-8	Spring washer	10
24	702770169	HPLMA220BMLE5E5B00	Hydraulic motor	1
25	702770025	AM60.02.102	Splined Hub	1
26	702770036	AM60.02.141	Motor Positioning Plate	1
27	506060183	GB893.1-62	Circlip	1
28	506060317	GB894.1-35	Ring Spacer	1
29	511022556	GB276-6007	Deep groove ball bearing	2

14. PARTS DIAGRAM 5 CUTTING HEAD (continued)

Dia No.	Number	Part Number	Part Description	Qty
30	702770028	AM60.02.105	Oil Seal	2
31	510020044	GB13871-FB-40X55X8	FB Oil Seal	2
32	509010007	GB1152-M6	Oil Cup	4
33	501011113	GB5783-M10X30	Bolt M10X30	8
34	802770042	AM60.02.011	Main bearing seat	1
35	501010758	GB5782-M12X60	Bolt M12X60	16
36	702770029	AM60.02.106	Blade	32
37	702770030	AM60.02.107	Blade Shackle	16
38	503010763	DIN985-M12	Locking Nut	20
39-1	802770046	AM60.02.012	Blade rotor shaft (60)	1
39-2	802780008	AM80.02.012	Blade rotor shaft (80)	1
39-3	806830006	AM100.02.012	Blade rotor shaft (100)	1
40	802770052	AM60.02.013	2nd Bearing Seat	1
41	703140005	MZ105.115	Gasket	1
42	506030037	GB93-12	Spring washer	1
43	501011125	GB5783-M12X25	Bolt M12X25	1
44	702770032	AM60.02.109	End cap	1
45	506010054	GB97.1-6	Plain washer	3
46	501011088	GB5783-M6X16	Bolt M6X16	3
47	506010057	GB97.1-12	Plain washer	4
48	802770055	AM60.02.014	Roller Shaft Seat	1
49	505011750	GB70.3-M12X30	Counter Sunk Bolt M12X30	2
50	501011127	GB5783-M12X35	Bolt M12X35	2
51-1	802770207	EFG120.012-AM60	Roller weldment (60)	1
51-2	802780018	EFG120.012-AM80	Roller weldment (80)	1
51-3	806830008	EFG120.012-AM100	Pulley weldment (100)	1
52	802770058	AM60.02.016	Roller Shaft	1

15. PTO SHAFT RESIZING

Safety: Ensure tractor & machine is stopped & keys out of ignition before carrying out any work. If you are not confident in carrying out the work consult your local supplier or mechanic.

Most PTO driven implements are supplied with a standard sized PTO shaft. As all tractors vary this often means cutting it down to size. Always replace worn or damaged PTO shafts.

Attach the machine to the tractor without the PTO shaft, raise the linkage so the PTO shaft is level/horizontal. Measure the length between tractor PTO and the machine's shaft. If the compressed (closed) PTO shaft length exceeds the one measured here then the driveline will need to be cut.

1. PTO length adjustment, first remove PTO shaft shielding.

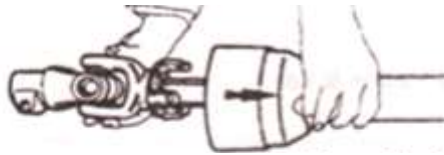

2. Shorten the driveline tubes to proper equal lengths.



3. Tidy edges of the drive tube with a file and clean all fillings from the tubes.



4. Shorten the equally long guard tubes to the same length as the driveline tubes.

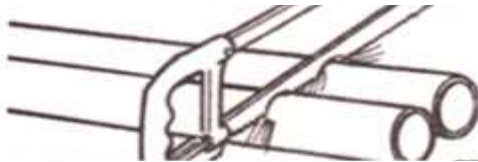

5. Grease the internal driveline tube.



6. Fit the guard on the shaft.



7. Make sure that the length allows for at least 16cm (6 inches) of overlap.



16. WINTON PRODUCT WARRANTY

We always strive to create great products, but when something does go wrong we have a strong network of resellers on hand throughout the UK to help out.

Warranty Claims

Before you get in touch here are 5 pieces of information your Winton reseller will need to progress your claim:

- Your invoice/order details - to include date of purchase
- Machine model number
- Machine serial number
- Details of the fault
- Images/videos of the fault

The Terms & Conditions

All products purchased as new are covered under our 12 month warranty from the date of purchase. During this period Winton will repair or replace defective parts free of charge. This warranty is given on the proviso that the product has been used and maintained according to the Owner's Manual.

Warranty is carried out on a return to reseller / manufacturer basis and excludes any labour or delivery / collection costs.

Exclusions

- Wearing parts are excluded; including but not limited to blades, belts and bearings.
- Modification of the product in any way will cease the manufacturers warranty.
- The machine is warranted for one year to the original purchaser, resale within the period will cease the warranty.
- Damage in transit is not covered. Claims will need to be made through the courier or your Winton reseller directly.
- Compensation for down-time, labour or loss of earnings is not covered by the warranty.
- No warranty extension will be granted for replacement parts fitted.
- Damage caused by continued use of a faulty machine will not be covered.

Your **Winton** reseller will provide their own terms and conditions upon purchase, consult this for any additional queries.

17. FAQ'S & TROUBLESHOOTING

Ensure tractor and machine is stopped & keys out of ignition before set-up/maintenance.

WAM Problem	Solution
Blade rotor blocking	<p>Clean off the cutter.</p> <p>Slow tractor speed.</p> <p>Change direction of rotor using the lever (when rotor is stopped).</p> <p>Replace any missing/damaged blades.</p> <p>Check hydraulic couplings are tight and no leaks in the system.</p>
Patches of uncut areas	<p>Run PTO at 540 PTO rpm, check PTO speed & tractor power output.</p> <p>Change into a lower gear on the tractor.</p> <p>Replace any missing/damaged blades.</p>
Excessive vibration	<p>Check rotor bearings & blade rotor.</p> <p>Replace blades.</p> <p>Check PTO shaft for damage and replace.</p> <p>Clean off the cutter.</p>
Blades scalping	<p>Raise cutting height.</p> <p>Change mowing pattern/route.</p> <p>Reduce speed when turning.</p>
Tractor loaded down by cutter	<p>Run at 540 PTO rpm.</p> <p>Change into a lower gear on the tractor.</p> <p>Clean off the cutter.</p> <p>Check power output on your tractor.</p>



W Winton

www.wintonmachinery.co.uk